



# SR42G Super Runner Gas Fryer

Project \_\_\_\_\_  
 Item \_\_\_\_\_  
 Quantity \_\_\_\_\_  
 CSI Section 11400 \_\_\_\_\_  
 Approval \_\_\_\_\_  
 Date \_\_\_\_\_

SR42G Super Runner Gas Fryer

## Models

SR42G



SR42G  
Shown with optional casters

## Standard Features

- 35-43-lb (17-21 liter) frypot oil capacity
- 105,000 Btu/hr. (26,481 kCal) (30.8 kW) input
- Thermo-tube design
- Stainless steel frypot, front, door, and backsplash/flue cover, aluminized sides
- Wire form basket hanger and two fry baskets  
5.375" x 6.375" x 12.16" (13.65 x 16.19 x 30.8 cm) insulated handles
- Wide cold zone
- Millivolt pilot system - requires no electrical hookup
- 6" (15 cm) adjustable steel legs

## Options & Accessories

- Stainless steel sides
- Casters -- set of 4

## Specifications

### **Basic Frying At Its Best -- Designed For All-Purpose Usage**

Maximize your profits by combining more efficiency with more capacity in this all-purpose, affordable fryer.

Fry a wide variety of products with the full size 14" x 14" (35 x 35 cm) frying area which easily accommodates items from french fries to main entree menu selections.

Make the most of your energy dollars with our exclusive Thermo-Tube design. The heating tubes provide a large oil contact surface. Controlled flow tube baffles maximize oil heat absorption. As a result, more energy is transferred to the oil and less goes unused up the vent. The benefits are quick heat-up time, low idle costs and low gas consumption per load of product cooked. The 1" (2.54 cm) drain valve makes cleaning fast and easy.

Minimize costly oil usage with the SR42 which utilizes only 35-43 lbs. (17-21 L) of oil for optimum cooking efficiency with a cook depth of 4.25" (10.8 cm). Plus, Dean's wide cold zone design protects oil integrity by trapping debris under the cooking area, preventing carbonization of particles and wasteful oil deterioration.

Assure rapid recovery with Dean's accurate mechanical thermostat which reduces time lost between loads and requires no electrical hookup.

Dean's SR42 fryers achieve long and dependable life through simplicity of design. The durable stainless steel baffles and rugged cast iron burners keep maintenance to a minimum.





# SR42G Super Runner Gas Fryer

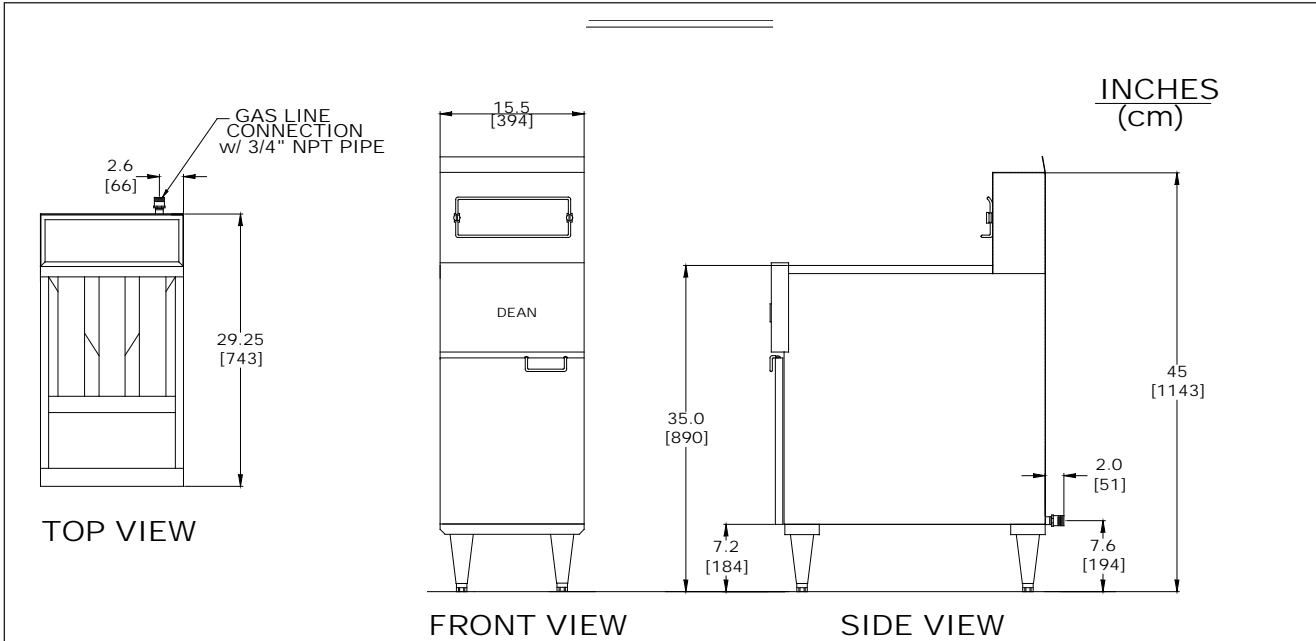

### DIMENSIONS

MIN./MAX. OIL CAPACITY	OVERALL SIZE (cm)				DRAIN VALVE (cm)	DRAIN VALVE HEIGHT (cm)	NO. OF TUBES	FRYING AREA (cm)	APPROXIMATE SHIPPING DIMENSIONS				
	WIDTH	DEPTH	OVERALL HEIGHT	WORK HEIGHT					CLASS	SHIPPING lbs./cu.ft. (kg/m <sup>3</sup> )	DIMENSIONS (cm)		
35-43 lbs. (17-21 L)	15.50" (39)	29.25" (74)	45" (114)	35" (89)	1" (2.54)	18.4" (47)	3	14" x 14" (35 x 35)	85	150 lbs./15 (68/0,42)	H 48.5" (123)	W 20.5" (52)	L 36" (91)

### POWER REQUIREMENTS

NATURAL OR LP GAS INPUT RATING	GAS CONNECTION	ELECTRICAL REQUIREMENT
105,000 Btu/hr. (26,481 kCal/hr.) (30.8 kW)	3/4" N.P.T. regulator not required	NONE

### SHORT TERM SPECIFICATION

Shall be DEAN free-standing cool zone deep fat fryer, Model SR42G. Only 15.50" (39 cm) wide, 35-43# (17-21 L) oil capacity, requiring 105,000 Btu/hr (26,481 kcal) (30.8 kW) natural or LP gas input (3/4" N.P.T. connection) and mechanical controls.

### ORDERING DATA

Please specify:  
 Natural or propane gas  
 Altitude -- if above 2000 ft. (610 m)

### NOTE:

DO NOT CURB MOUNT.

Model # \_\_\_\_\_  
 CSI Section 11400