

Item
Model
ProjectName

TRS - 1 Speed

With the TRS universal vegetable slicer it is possible to quickly and easily make over 70 different types of cuts for the stylish and imaginative presentation of salads, garnishings, macedoines, chips and many other combinations.

FEATURES

- Wide range of functions: slicing, mincing, grating, shredding and cutting into chips or cubes of all sizes.
- Plate speed at 360 RPM for precise cutting, slicing and dicing.
- Large round hopper (215cm²) allows food of greater dimension to be processed.
- Feeding arm with integrated long-vegetable hopper (tube pusher), 60mm in diameter. Ideal for carrots, zucchini, cucumbers, etc.
- Base inclined at 20° provides easy loading and unloading.
- High discharge zone permits the use of deep GN containers (up to 20cm).
- Feeding arm and hopper are made entirely in stainless steel and ABS. Aluminium motor housing.
- Plates and ejector may be removed in seconds by opening the cover.
- All parts that come into contact with the food are in stainless steel or plastic, can be removed for easy cleaning and are dishwasher safe.

Vegetable slicers



DITO**Electrolux**

- Sleek, compact and innovative design. Rounded corners allow for easy cleaning.
- IPX5 touch-control, waterproof panel. Green button indicates ON, Red button indicates OFF. Pulse control for precise slicing.
- Asynchronous industrial motor with no brushes for high reliability and quiet functioning. Stainless steel motor shaft.
- Two separate safety switches stop the machine in order to protect the operator from potentially dangerous conditions. One senses when the handle is lifted and/or the shaft is removed and the other senses when the cover is opened.
- IP24 throughout entire machine.

Specifications

MODEL	TRS1V371 603312	TRS1V501 603311	TRS1V503 603313	TRS1V3716 603387	TRS1V5016 603519
External dimensions - mm					
width	252	252	252	252	252
depth	500	500	500	500	500
height	502	502	502	502	502
Speed - rpm	360	360	360		
Cutting capacity - kg/h					
carrots	160	350	350	350	350
dicing	600	600	600	600	600
Cutting capacity - kg/h					
potatoes	550	550	550	550	550
Power - kW					
installed-electric	0.37	0.5	0.5	0.37	0.5
Net weight - kg.	21.4	21.4	21.4	21.4	21.4
Supply voltage	220...240 V, 1N, 50	220...240 V, 1N, 50	200...240/380...440 V, 3, 50/60	208...240 V, 1N, 60	208...240 V, 1N, 60



DITO**Electrolux**

Optional accessories

CODE	DESCRIPTION	TRS1V371 603312	TRS1V501 603311	TRS1V503 603313	TRS1V3716 603387	TRS1V5016 603519
653568	DICING GRID 10 MM FOR VEGETABLE SLICER	✓	✓	✓	✓	✓
653569	DICING GRID 12 MM FOR VEGETABLE SLICER	✓	✓	✓	✓	✓
653570	DICING GRID 20 MM FOR VEGETABLE SLICER	✓	✓	✓	✓	✓
653566	DICING GRID 5 MM FOR VEGETABLE SLICER	✓	✓	✓	✓	✓
653567	DICING GRID 8 MM FOR VEGETABLE SLICER	✓	✓	✓	✓	✓
653573	GRID FOR CHIPS 10MM FOR VEGETABLE SLICER	✓	✓	✓	✓	✓
653571	GRID FOR CHIPS 6MM FOR VEGETABLE SLICER	✓	✓	✓	✓	✓
653572	GRID FOR CHIPS 8MM FOR VEGETABLE SLICER	✓	✓	✓	✓	✓
653749	S/S DISC WITH CORRUGATED S-BLADES 2 MM	✓	✓	✓	✓	✓
653750	S/S DISC WITH CORRUGATED S-BLADES 3 MM	✓	✓	✓	✓	✓
653751	S/S DISC WITH CORRUGATED S-BLADES 6 MM	✓	✓	✓	✓	✓
653778	S/S GRATING DISC FOR KNODELN AND BREAD	✓	✓	✓	✓	✓
653779	S/S GRATING DISC FOR PARMESAN AND BREAD	✓	✓	✓	✓	✓
653753	S/S PRESS/CORRUGATED DISC S-BLADES 10 MM	✓	✓	✓	✓	✓
653752	S/S PRESS/CORRUGATED DISC S-BLADES 8 MM	✓	✓	✓	✓	✓
653739	S/S PRESS/SLICE DISC WITH S-BLADES 10 MM	✓	✓	✓	✓	✓
653741	S/S PRESS/SLICE DISC WITH S-BLADES 12 MM	✓	✓	✓	✓	✓
653742	S/S PRESS/SLICE DISC WITH S-BLADES 13 MM	✓	✓	✓	✓	✓
653734	S/S PRESS/SLICE DISC WITH S-BLADES 5 MM	✓	✓	✓	✓	✓
653736	S/S PRESS/SLICE DISC WITH S-BLADES 6 MM	✓	✓	✓	✓	✓
653738	S/S PRESS/SLICE DISC WITH S-BLADES 8 MM	✓	✓	✓	✓	✓
653740	S/S PRESS/SLICE DISC(MOZZ)S-BLADES 10 MM	✓	✓	✓	✓	✓
653748	S/S SHREDDING DISC WITH S-BLADES 10X10MM	✓	✓	✓	✓	✓
653743	S/S SHREDDING DISC WITH S-BLADES 2X2 MM	✓	✓	✓	✓	✓
653744	S/S SHREDDING DISC WITH S-BLADES 3X3 MM	✓	✓	✓	✓	✓
653745	S/S SHREDDING DISC WITH S-BLADES 4X4 MM	✓	✓	✓	✓	✓
653746	S/S SHREDDING DISC WITH S-BLADES 6X6 MM	✓	✓	✓	✓	✓
653747	S/S SHREDDING DISC WITH S-BLADES 8X8 MM	✓	✓	✓	✓	✓
653728	S/S SLICING DISC WITH S-BLADES 0,6 MM	✓	✓	✓	✓	✓
653729	S/S SLICING DISC WITH S-BLADES 1 MM	✓	✓	✓	✓	✓
653730	S/S SLICING DISC WITH S-BLADES 2 MM	✓	✓	✓	✓	✓
653731	S/S SLICING DISC WITH S-BLADES 3 MM	✓	✓	✓	✓	✓
653732	S/S SLICING DISC WITH S-BLADES 4 MM	✓	✓	✓	✓	✓
653733	S/S SLICING DISC WITH S-BLADES 5 MM	✓	✓	✓	✓	✓
653735	S/S SLICING DISC WITH S-BLADES 6 MM	✓	✓	✓	✓	✓
653737	S/S SLICING DISC WITH S-BLADES 8 MM	✓	✓	✓	✓	✓
653783	S/S WORK TABLE+FOLDING SHELVES+DISK RACK	✓	✓	✓	✓	✓
653795	SET DISCS BISTROT (C2S, C5S, J2X)	✓	✓	✓	✓	✓
653786	SET GASTRO(C2S,C5S,J2X,AS4X,C10PS,MT10T)	✓	✓	✓	✓	✓
653773	STAINLESS STEEL GRATING DISC 2 MM	✓	✓	✓	✓	✓
653774	STAINLESS STEEL GRATING DISC 3 MM	✓	✓	✓	✓	✓
653775	STAINLESS STEEL GRATING DISC 4 MM	✓	✓	✓	✓	✓
653776	STAINLESS STEEL GRATING DISC 7 MM	✓	✓	✓	✓	✓
653777	STAINLESS STEEL GRATING DISC 9 MM	✓	✓	✓	✓	✓
653180	TABLE+SHELF+BN+MT POLYCARBONATE TRAY	✓	✓	✓	✓	✓



DITO**Electrolux**

Installation drawings

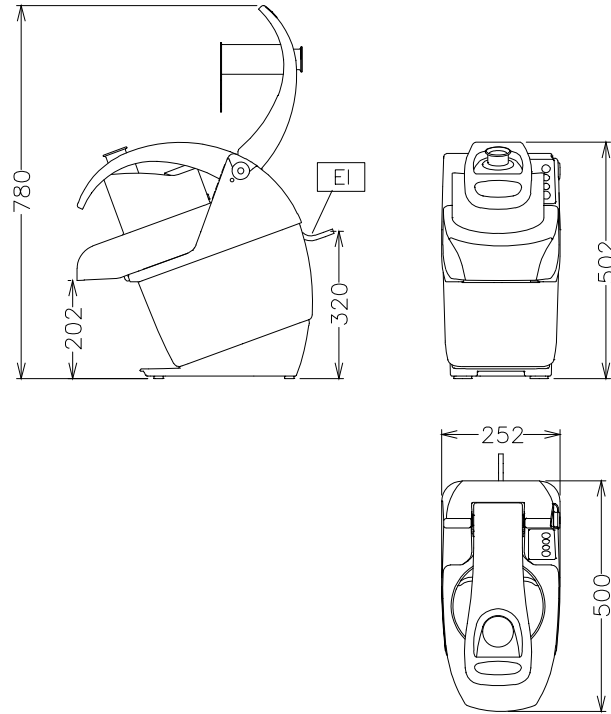
603312, 603519, 603387, 603313, 603311

MODEL	TRS1V371 603312	TRS1V501 603311	TRS1V503 603313	TRS1V3716 603387	TRS1V5016 603519
EI - Electrical connection	220...240 V, 1N, 50	220...240 V, 1N, 50	200...240/380...440 V, 3, 50/60	208...240 V, 1N, 60	208...240 V, 1N, 60

The manufacturer reserves the right to modify and make improvements to the products without giving prior warning. Dimensions, illustrations, technical data, weights, etc. are given as an indication only.



www.dito-electrolux.com

Vegetable slicers

AAAC010

