



solo per professionisti

Sirman Spa
 Viale dell'Industria 9/11
 35010 PIEVE DI CURTAROLO (PD), Italy
 Tel./Fax. +39 049 9698666 / +39 049 9698688
 email: info@sirman.com



Sirman Slicers , model Topaz 250c :

- Anodized cast aluminium alloy.
- Lat base for easy cleaning.
- Strong and silent-running asynchronous motor.
- Reliable poliV belt drive.
- Forged, hardened large thickness blades.
- Carriage running on self-lubricating bushes.
- Cast-in sharpener.
- Teflon coated or toothed blades available
- 25° blade inclination.



Underside motor protection plate



Data sheet

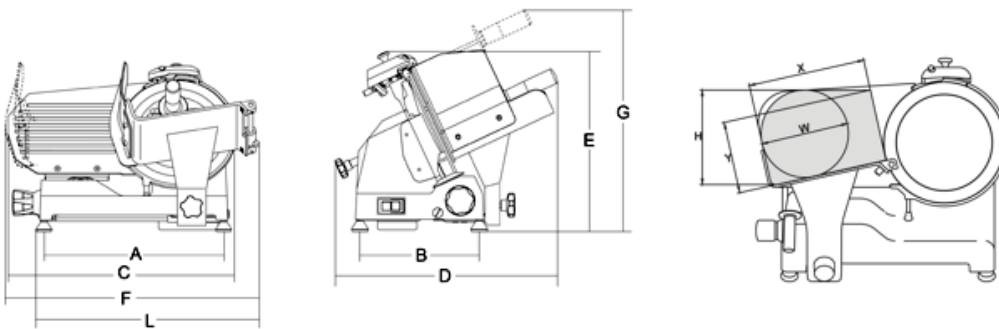

Technical data

| | |
|-----------------|--------------------|
| Model | TOPAZ 250C |
| ø Blade | mm 250 - inch. 10" |
| Motor | Watt 145 - Hp 0,20 |
| Cut thickness | mm 13 |
| Run of carriage | mm 240 |
| Hopper | mm 230x230 |
| A | mm 380 |
| B | mm 250 |
| C | mm 480 |
| D | mm 410 |
| E | mm 360 |
| F | mm 500 |
| G | mm 410 |
| L | mm 475 |
| X | mm 185 |
| Y | mm 165 |
| H | mm 180 |
| W | mm 180 |
| Net weight | kg 14 |
| Shipping | mm 600x500x420 |

| | |
|--------------|----------|
| Gross weight | kg 16 |
| HS-CODE | 84385000 |