

The science behind successful coffee shops



2026



Kanteen[®]
S I N C E 1 9 5 0

CONFECTIONARY CABINET



MADE 
IN 
INDIA 

CAKE
PASTRY
SWEETS

ONE SOLUTION FOR
KEEPING ALL THIS **FRESH!**



@kanteenindia



**PTW
06**

PASTRY CABINET PTW06

| | |
|----------------------|------------------------------|
| Gross Volume (Ltr.) | 232 |
| Net Volume (Ltr.) | 205 |
| External Dims. (mm) | 600 (W) x 665 (D) x 1235 (H) |
| Internal Dims. (mm) | 510 (W) x 596 (D) x 710 (H) |
| Foot Print (Sq Mtr.) | 0.4 |
| Refrigerant | R290 |
| Temperature Range | 2° to 10° C |
| Shelves (Nos.) | Base + 3 Shelves |

AVAILABLE VARIANTS

HOT CABINET | AMBIENT CABINET



**PTW
09**

PASTRY CABINET PTW09

| | |
|----------------------|------------------------------|
| Gross Volume (Ltr.) | 360 |
| Net Volume (Ltr.) | 320 |
| External Dims. (mm) | 900 (W) x 665 (D) x 1235 (H) |
| Internal Dims. (mm) | 810 (W) x 570 (D) x 710 (H) |
| Foot Print (Sq Mtr.) | 0.6 |
| Refrigerant | R290 |
| Temperature Range | 2° to 10° C |
| Shelves (Nos.) | Base + 3 Shelves |

AVAILABLE VARIANTS

HOT CABINET | AMBIENT CABINET

- Adjustable Glass Shelves
- Electronic Temperature Control
- Roller Wheels (PTW 06)
- LED Lamps for Individual Shelves
- Water fall shelf design for better display
- Faster Pull Down
- Stainless Steel Inner Bottom Shelf
- On/Off Switch for Lights and Glass Heater
- Strong shelving
- Front Heated Glass Castor Wheel for Easy Movement Wire on Tube
- Condenser for Low Maintenance



PASTRY CABINET PTW12

| | |
|----------------------|-------------------------------|
| Gross Volume (Ltr.) | 500 |
| Net Volume (Ltr.) | 435 |
| External Dims. (mm) | 1200 (W) x 665 (D) x 1235 (H) |
| Internal Dims. (mm) | 1110 (W) x 570 (D) x 710 (H) |
| Foot Print (Sq Mtr.) | 0.8 |
| Refrigerant | R290 |
| Temperature Range | 2° to 10° C |
| Shelves (Nos.) | Base + 3 Shelves |



**PTW
12**

AVAILABLE VARIANTS

- HOT CABINET
- AMBIENT CABINET
- LOW COST VARIANT
- STAINLESS STEEL VARIANT

PASTRY CABINET PTW15

| | |
|----------------------|-------------------------------|
| Gross Volume (Ltr.) | 660 |
| Net Volume (Ltr.) | 577 |
| External Dims. (mm) | 1500 (W) x 665 (D) x 1235 (H) |
| Internal Dims. (mm) | 1410 (W) x 570 (D) x 710 (H) |
| Foot Print (Sq Mtr.) | 1 |
| Refrigerant | R290 |
| Temperature Range | 2° to 10° C |
| Shelves (Nos.) | Base + 3 Shelves |



**PTW
15**

AVAILABLE VARIANTS

- HOT CABINET | AMBIENT CABINET

- Adjustable Glass Shelves
- Electronic Temperature Control
- Roller Wheels (PTW 06)
- LED Lamps for Individual Shelves
- Water fall shelf design for better display
- Faster Pull Down
- Stainless Steel Inner Bottom Shelf
- On/Off Switch for Lights and Glass Heater
- Strong shelving
- Front Heated Glass Castor Wheel for Easy Movement
- Wire on Tube
- Condenser for Low Maintenance



Golden Confectionary Cabinet

FEATURES

- Elegantly Golden Radiance
- Sturdy Waterfall Shelving for Optimal Display
- Durable Shelves Designed to Support Mithai Weights
- Seamless Customization with Adjustable Shelving
- Secure Power System with Anti-Rodent Conduit Protection

SPECIFICATIONS

| | PTW09HC-GD | PTW12HC-GD | PTW15HC-GD |
|--------------------------|------------------------------|-------------------------------|-------------------------------|
| Gross Volume (Ltr.) | 360 | 500 | 660 |
| Net Volume (Ltr.) | 320 | 435 | 577 |
| External Dimensions (mm) | 900 (W) x 665 (D) x 1235 (H) | 1200 (W) x 665 (D) x 1235 (H) | 1500 (W) x 665 (D) x 1235 (H) |
| Internal Dimensions (mm) | 810 (W) x 570 (D) x 710 (H) | 1110 (W) x 570 (D) x 710 (H) | 1410 (W) x 570 (D) x 710 (H) |
| Foot Print (Sq. Mtr.) | 0.6 | 0.8 | 1 |
| Refrigerant | R290 | R290 | R290 |
| Temperature Range | 2 to 100 C | 2 to 100 C | 2 to 100 C |
| Shelves (Nos.) | 3 + 1 | 3 + 1 | 3 + 1 |

To Order Call: +91-8100-777-000



KANTEEN INDIA EQUIPMENTS CO.

CB-59, Sector 1, Salt Lake City, Kolkata 700064, WB, India

Customer Care: +91-8100-777-000

E-mail: sales@kanteenindia.com | service@kanteenindia.com

Website: www.kanteenindia.com



SCAN ME



VERTICAL GOLDEN PASTRY CABINET **PTW775VHC-P**



SPECIFICATIONS

| | |
|---|------------------|
| Gross Volume: | 658 L |
| Net Volume: | 635 L |
| External Dimension (mm) WxDxH: | 720 x 822 x 1937 |
| Internal Dimension (mm) WxDxH: | 640 x 680 x 1631 |
| Product Display Area (m ²): | 0.98 |
| Temperature Range: | 2°C to 10°C |
| Footprint (m ²): | 0.59 |
| No. of Shelves: | 7+1 |
| Refrigerant: | R-290 |

VERTICAL GOLDEN PASTRY CABINET **PTW1165VHC-P**



SPECIFICATIONS

| | |
|---|-------------------|
| Gross Volume: | 820 L |
| Net Volume: | 771 L |
| External Dimension (mm) WxDxH: | 1025 x 735 x 1968 |
| Internal Dimension (mm) WxDxH: | 945 x 590 x 1631 |
| Product Display Area (m ²): | 1.27 |
| Temperature Range: | 2°C to 10°C |
| Footprint (m ²): | 0.75 |
| No. of Shelves: | 7+2 |
| Refrigerant: | R-290 |

To Order Call: +91-8100-777-000



Kanteen[®]
SINCE 1950

VERTICAL PASTRY CABINET



To Order Call: +91-8100-777-000

HIGH ON VISIBILITY &
BIG ON FRESHNESS



SCAN ME



@kanteenindia



Introducing the All-New Vertical Pastry Cabinet

PTW775VHC-P

Designed for Modern
Bakeries & Cafés

A perfect mix of stylish design, smart use of space, and powerful performance – this cabinet make your desserts look amazing while keeping them fresh and Delicious.



To Order Call: +91-8100-777-000

SPECIFICATIONS

| | |
|------------------------------------|--|
| Volume | 658 ltrs |
| External Dimensions mm: | 720 (W) x 822 (D) x 1937 (H) |
| Internal Dimensions mm: | 640 (W) x 680 (D) x 1631 (H) |
| Temperature Range: | 2°C to 10°C 4.23 Units/Day |
| Energy Efficiency: Shelf: | 7+1 nos. 0.98 sq. m 4 |
| Display Area: Illumination: | Vertical LEDs on Front & Rear |

KEY FEATURES



APPEALING DESIGN

Slim vertical build, ideal for compact or tight spaces



PRECISE TEMPERATURE CONTROL

Ensures optimal freshness and display conditions for cakes



EDGE-LIT ILLUMINATION

Stylish LED lighting enhances product visibility and display appeal



HIGH CAPACITY

7+1 shelves can hold up to 30-32 cakes 1 kg (each)



THREE-SIDE VISIBILITY

Crystal-clear glass on the front and both sides for maximum product visibility

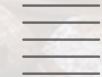

ROBUST SHELVING

High-density shelves designed to hold 4-5 cakes each



ENERGY EFFICIENT

Low power consumption helps reduce operating costs



@kanteenindia



KANTEEN INDIA EQUIPMENTS CO.

CB-59, Sector 1, Salt Lake City, Kolkata 700064, WB, India

Customer Care: +91-8100-777-000

E-mail: sales@kanteenindia.com | service@kanteenindia.com

Website: www.kanteenindia.com





The whole Italian espresso tradition in models with a technological heart. Astoria's traditional range of coffee machines guarantees reliability and service quality to all types of users. From the most expert Barista, finding amusement in playing with the coffee, to the one instead who needs a speedy and efficient machine for dealing with large volumes. Or yet again, to the one that wants to guarantee maximum quality to even those few who have always been faithful customers. A different machine for each of these, but always Astoria.

TRADITIONAL ESPRESSO MACHINES



Astoria[®]
Think espresso

☐ ————— ☐
COFFEE MACHINE
SEMI-AUTOMATIC
☐ ————— ☐



☐ ————— ☐

STORM
BARISTA ATTITUDE



SCAN ME

MADE IN ITALY



TECHNICAL DESCRIPTION

| MODEL | COFFEE WATER TANK | DIMENSIONS (WxDxH)MM | STEAM HEATING | POWER (Watts/Hrs) | VOLTAGE | WEIGHT (Kg) |
|-------|-------------------|----------------------|---------------|-------------------|--------------|-------------|
| 2 Gr | (1.2 Ltrs) X2 | 1035X618X500 | 8.5 Ltrs | 5800 | 440/50Hz/3pH | 85 |
| 3 Gr | (1.2 Ltrs) X3 | 1175X618X500 | 8.5 Ltrs | 5800 | 440/50Hz/3pH | 105 |

TECHNICAL FEATURES

- Available 2,3 and 4 Groups
- LED backlight with light-intensity change
- Energy Saver: automatic On/Off and Standby
- Digital boiler pressure display and control
- Digital delivery pressure display
- User interface: a display for each group; choice of skin type
- Hydraulic circuit efficiency control system
- Configuration of brewing curves for each key
- FRC version: brewing curve and customization
- Super Dry: dry steam dispensing system

TOTAL CONTROL OF THE MANUAL DISPENSING - Storm is a competition machine that guarantees total control of the manual dispensing of mono-origin coffee and, at the same time, is suitable for use according to memorized brewing curves, which can enhance perfume and aromatic notes constantly.

CUSTOMIZABLE NOBLE MATERIALS - Enhanced by wood accents which can be personalized with different wood types and stains, the Storm coffee machine arouses emotions and was built in tune with the most technologically accurate studies.

PRACTICALITY - In Storm, the basin adjustment lets the barista keep the cup at the best level for the beverage being made. Routine cleaning operations are also more fluid and uniform thanks to the rounded shape, whereas washing is facilitated by the vertical extraction of the basin.

Multiple Heating Technology

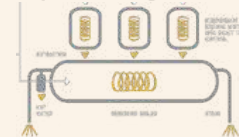

COLOURS

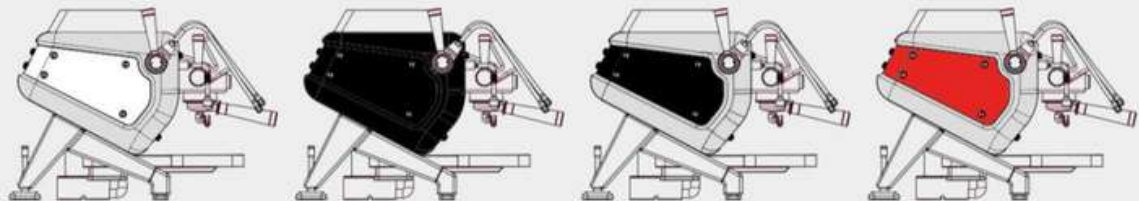

SOTTO BANCO

☐ ————— ☐
COFFEE MACHINE
SEMI-AUTOMATIC
☐ ————— ☐



☐ ————— ☐
Sotto Banco is a stylish under counter machine, featuring sleek raised groups extending from the counter, with both the service boiler and auxiliary equipment located under the counter.



SOTTO BANCO

MULTI BOILER TECHNOLOGY



Sotto Banco has one big service boiler for hot water and steam in the module under the counter. On the counter are available two or three boilers dedicated to coffee.

All the boilers in Sotto Banco are in Stainless steel AISI 316L.

Capacity of the **coffee boiler** is:

V 2 groups machine: **2 x 1,5l**

V 3 groups machine: **3 x 1,5l**

Fully saturated coffee group connected directly to the coffee boiler means a perfect temperature stability.

Service boiler for steam and hot water is located in the module under the counter. The capacity of the service boiler is:

V 2 groups machine: **9l**

V 3 groups machine: **12l**



High capacity for high performance in steam and hot water. In the module under the counter there are the service boiler, auxiliary equipment and softener.



INTERFACE

Sotto Banco fits a **new interface**.

Buttons pad for each group with 4 buttons for the following operations:

- Start/Stop button
- Single shot
- Double shot
- Flush

Available a version with **6 buttons**

4,3" TFT display available on the module under the counter.



STEAM WAND

Sotto Banco features **two or three steam wands**, barista style, **cold touch**.

With a special system by Rocket, **steam is dry** and with a minimal initial condensation (**Patent Pending**).

Thanks to the big capacity of the service boiler in Sotto Banco, continuous use of steam is guaranteed with **no drop in performance** even when using two or three wands at the same time.

With the joystick, the control of the speed of the steam is always guaranteed.



TECHNICAL INFORMATION

| | 2 GROUPS | 3 GROUPS |
|-----------------------|---------------------------------------|---|
| Hot water spout | 1 | 2 |
| Technology | Multi Boiler | |
| Portion Control | Automatic | |
| Coffee Boiler | 2 x 1,5 l | 3 x 1,5 l |
| Power - Coffee Boiler | 2,4 kW | 3,6 kW |
| Main Boiler | 9,0 l | 12,0 l |
| Power – Main Boiler | 3,0 kW | 3,0 kW |
| W x D x H (mm) | 890 x 386 x 355 (tall version 400) | 1.300 x 386 x 355 (tall version 400) |
| Total Power | 5,7 kW | 6,9 kW |

| | 2 GROUPS | 3 GROUPS |
|---------------------------|------------------------------|----------|
| Under counter module (mm) | 450 x 512 x 740 (W x D x H) | |
| Bodywork | Stainless steel AISI 304 | |
| Boiler Material | Stainless steel AISI 316L | |
| Thermal Control | PID / Pressure transducer | |
| Steam Wands | Stainless steel + cool touch | |
| Cup Height (mm) | 85 (tall version: 130) | |
| Shot Timer | Standard | |

RE DOPPIA

☐ ————— ☐
COFFEE MACHINE
SEMI-AUTOMATIC
☐ ————— ☐



New **RE Doppia** is an automatic traditional machine that combines the latest Rocket Espresso technology with a specification and level of componentry that represents a machine brought to market with an aggressive approach to price versus specification. This does not mean the Doppia is any less of a machine, rather with clever engineering, the Doppia clearly outperforms most machines in this class.



SCAN ME

MADE IN ITALY



DESIGN

Unique design for new RE Doppia from Rocket: a machine that stand for its elegance and robustness.

COLOR VERSION

STAINLESS STEEL

BLACK

WHITE



DUAL BOILER TECHNOLOGY



RE Doppia has two boiler in Stainless steel AISI 316L. **One boiler dedicated to the coffee** and one big boiler for steam and hot water.

INTERFACE



Buttons pad for each group with 4 buttons



For each group there's a small display, when the machine is not working, the **temperature** of the coffee group shows



4,3" TFT service display on the front panel of the machine

STEAM WAND



Two steam wands, barista style. Long steam wand to make easy the task of the barista, **cold touch**.

With a special system by Rocket **steam is dry** and with a minimal initial condensation.

TALL CUP VERSION



Can be configured in standard version or Tall Cup: on article number for two version thanks to the adjustable drip tray. The height of the drip tray can be adjusted from 85 mm for the standard version up to 125mm for the Tall cup.

TECHNICAL INFORMATION

| | 2 GROUPS | 3 GROUPS |
|-----------------------|-----------------|-------------------|
| Technology | Dual Boiler | |
| Portion Control | Automatic | |
| Coffee Boiler | 4,0 l | 6,3 l |
| Power - Coffee Boiler | 1,7 kW | 2,0 kW |
| Main Boiler | 9,0 l | 12,0 l |
| Power – Main Boiler | 3,0 kW | 3,5 kW |
| W x D x H (mm) | 848 x 603 x 500 | 1.060 x 603 x 500 |
| Total Power | 5,0 kW | 5,8 kW |



| | 2 GROUPS | 3 GROUPS |
|-----------------|------------------------------|----------|
| Bodywork | Stainless steel AISI 304 | |
| Boiler Material | Stainless steel AISI 316L | |
| Thermal Control | PID / Pressure transducer | |
| Steam Wands | Stainless steel + cool touch | |
| Cup Height (mm) | 85 (tall version: 125) | |
| Shot Timer | Standard | |

☐ ————— ☐
COFFEE MACHINE
HYBRID
☐ ————— ☐



☐ ————— ☐

HYbrid
Easy Pleasure



MADE IN ITALY

HYbrid
Easy Pleasure



TECHNICAL DESCRIPTION

| MODEL | COFFEE WATER TANK | DIMENSIONS (WxDxH)MM | EQUIPPED WITH | POWER (Watts/Hrs) | VOLTAGE | WEIGHT (Kg) |
|-------------------------|-------------------|----------------------|---------------|-------------------|--------------|-------------|
| 1 Gr - 2 Coffee Grinder | (1.2 Ltrs) X1 | 622X583X673 | 4.0 Ltrs | 4800 | 440/50Hz/3pH | 85 |
| 2 Gr - 2 Coffee Grinder | (1.2 Ltrs) X2 | 822X673X594 | 8.0 Ltrs | 6700 | 440/50Hz/3pH | 118 |

TECHNICAL FEATURES

- The auto-steamer wand allows milk to be frothed in set temperature. The wand has auto cut off feature which would stop the frothing at the right temperature as per our requirement. This saves up on a lot of time during rush hour and ensures consistency every time.
- Since the entire grinding, dosing and compressing procedure is completely automated, it makes it easy for anyone to make coffee.
- Filter holders with a patented front insertion system and automatic lock.
- Thanks to the IMP Multiboiler technology and sophisticated electronics, the parameters of the HYbrid can be adjusted to a high degree, which impacts the coffee being extracted.
- HYbrid allows anyone, even those who do not have any experience, to use the machine: the beverage dispenses with one touch.

COLOURS

WHITE

BLACK



☐ ————— ☐
COFFEE MACHINE
SEMI-AUTOMATIC
☐ ————— ☐



Plus 4 You TS





TECHNICAL DESCRIPTION

| MODEL | BOILER CAPACITY (Ltrs) | DIMENSIONS (WxDxH)MM | EQUIPPED WITH | POWER (Watts/Hrs) | VOLTAGE | WEIGHT (Kg) |
|------------------|------------------------|----------------------|--|-------------------|--------------|-------------|
| Plus 4 You SAE 2 | 10.5 | 835X565X575 | 2 Group Head 1 Hot water outlet 2 Steam wand | 4700 | 440/50Hz/3pH | 82 |

TECHNICAL FEATURES

- Available 2 and 3 Groups
- Electronic dispensing of servings
- Automatic water refill
- Hot water mixing system
- Electronically controlled cup heater
- LED illumination of workspace
- Raised groups
- Retractable raised cup grates
- USB port for programming

- **Functions language options**- Italian, English, German, French, Spanish, Portuguese.
- **Programming** - of the temperature of the coffee water tank for each group
- **Display** - With programming of the steam boiler pressure
- **Easier Service** - Diagnostic messages display
- **Multifunctional Touch Screen** Color display



COLOURS

Body

White

Red

Gray

Details

Chrome

Matte
Black

Matte
Black



☐ ————— ☐
COFFEE MACHINE
SEMI-AUTOMATIC
☐ ————— ☐



Sabrina

TECHNICAL DESCRIPTION

| MODEL | BOILER CAPACITY (Ltrs) | DIMENSIONS (WxDxH)MM | EQUIPPED WITH | POWER (Watts/Hrs) | VOLTAGE | WEIGHT (Kg) |
|---------------|------------------------|----------------------|--|-------------------|--------------|-------------|
| SABRINA SAE 2 | 10.5 | 835X582X582 | 2 Group Head 1 Hot water outlet 2 Steam wand | 4200 | 220/50Hz/3pH | 82 |

TECHNICAL FEATURES

- Available 2 and 3 Groups
- Electronic version with volumetric dosage and programming of 6 independent coffee doses for each group.
- Automatic water refill (A.W.R.)
- Automatic hot Water, Electronic cup-warmer
- Control light for water level check (through display in the SAE Display version)
- White lights on the side panels
- **Icon Menu** - Intuitive and immediate browsing of the "touch screen" menu.
- **Parameters detail** - Easy adjustment of machine parameters.
- **Flow Chart** - Display of the real trend of the infusion throughout the extraction cycle.
- **Timer Function** - View of the dispensing time for each group.

Body

Detail

COLOURS

White

Black

Brown
Details

Steel

Steel

Steel

MADE IN ITALY



☐ ————— ☐
COFFEE MACHINE
SEMI-AUTOMATIC
☐ ————— ☐



HOLLYWOOD

A film by Astoria

Technical product sheet

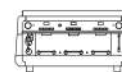

| | | 2GR | 3GR |
|--------------|--------------|-------------------|-------------------|
| Voltage | V | 220-240V/380-415V | 220-240V/380-415V |
| Rated power | W | 3.900W - 4.200W | 5.600W-6.000W |
| Boiler | Lt US gal | 10,5 2,77 | 17 4,49 |
| Width | mm in | 790 31,1 | 1040 40,94 |
| Depth | mm in | 580 22,83 | 580 22,83 |
| Height | mm in | 540 21,25 | 540 21,25 |
| Net weight | kg lb | 72 158 | 90 198 |
| Gross weight | kg lb | 84 185 | 102 224 |

Colours

| | White | White | Red | Blue | Green |
|------|---|--|---|---|---|
| Body |  |  |  RAL 3003 |  RAL 5001 |  RAL 6002 |



☐ ————— ☐
COFFEE MACHINE
SEMI-AUTOMATIC
☐ ————— ☐



Core⁶⁰⁰



MADE IN ITALY



TECHNICAL DESCRIPTION

| MODEL | BOILER CAPACITY (Ltrs) | DIMENSIONS (WxDxH)MM | EQUIPPED WITH | POWER (Watts/Hrs) | VOLTAGE | WEIGHT (Kg) |
|-------------------|------------------------|----------------------|--|-------------------|--------------|-------------|
| Core 600 SAE 2 | 10.5 | 747X493X511 | 2 Group Head 1 Hot water outlet 2 Steam wand | 4000 | 220/50Hz/3pH | 75 |

TECHNICAL FEATURES

- Available 2 and 3 Groups
- Programming of coffee doses from push-button panel
- Auxiliary switches for coffee dispensing
- Astoria ergonomic filter holders
- Thermo-syphon circulation hydraulic circuit
- Built-in motor pump
- Volumetric dosing (single or double shot)
- Automatic water refills (A. W. R.)
- Indicator boiler pressure and level
- Temperature/pressure setting
- Supply/delivery pressure display
- Firmware release display
- Beverage delivery chart display
- Energy consumption chart display



COLOURS

Body



Steel



White



Red

☐ ————— ☐
COFFEE MACHINE
SEMI-AUTOMATIC
☐ ————— ☐



☐ ————— ☐

Core²⁰⁰



MADE IN ITALY



TECHNICAL DESCRIPTION

| MODEL | BOILER CAPACITY (Ltrs) | DIMENSIONS (WxDxH)MM | EQUIPPED WITH | POWER (Watts/Hrs) | VOLTAGE | WEIGHT (Kg) |
|-------------------|------------------------|----------------------|--|-------------------|--------------|-------------|
| Core 200 SAE 2 | 10.5 | 747X493X511 | 2 Group Head 1 Hot water outlet 2 Steam wand | 3700 | 220/50Hz/3pH | 61 |

TECHNICAL FEATURES

- Available 2 and 3 Groups
- Backlit Astoria logo
- All bodywork, excluding curbs, are made of sheet metal making a solid and resistant machine.
- Shot Timer Indication of the extraction times for each group
- Larger diameter steam nozzles Allow more consistency in the quality of the steam, improved milk frothing.
- Volumetric dosing (single or double shot)
- Automatic water refills (A. W. R.)



COLOURS

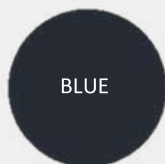

☐ ————— ☐
COFFEE MACHINE
SEMI-AUTOMATIC
☐ ————— ☐



Pratic Avant





TECHNICAL DESCRIPTION

| MODEL | BOILER CAPACITY (Ltrs) | DIMENSIONS (WxDxH)MM | EQUIPPED WITH | POWER (Watts/Hrs) | VOLTAGE | WEIGHT (Kg) |
|--------------------|------------------------|----------------------|--|-------------------|--------------|-------------|
| Pratic Avant SAE 1 | 6 | 560X560X540 | 1 Group Head 1 Hot water outlet 1 Steam wand | 2900 | 220/50Hz/1pH | 59 |
| Pratic Avant SAE 2 | 10.5 | 770X560X540 | 2 Group Head 1 Hot water outlet 2 Steam wand | 3600 | 440/50Hz/3pH | 72 |

TECHNICAL FEATURES

- Available from 1 to 3 groups
- Body with panels in stainless steel and in painted steel.
- Boiler and pipes made in copper.
- Double gauges for boiler and pump pressure control.
- Pilot light indicating the water level in the boiler
- Built-in motor pump
- Double scale manometre for displaying the boiler and pump pressure
- Volumetric dosing (single or double shot)
- Automatic water refills (A. W. R.)



COLOURS

Body

White

Red

Glossy Black

Details

Stainless Steel

Stainless Steel

Stainless Steel

☐ ————— ☐
COFFEE MACHINE
SEMI-AUTOMATIC
☐ ————— ☐



☐ **Tanya R**





TECHNICAL DESCRIPTION

| MODEL | BOILER CAPACITY (Ltrs) | DIMENSIONS (WxDxH)MM | EQUIPPED WITH | POWER (Watts/Hrs) | VOLTAGE | WEIGHT (Kg) |
|-------------|------------------------|----------------------|--|-------------------|--------------|-------------|
| Tanya SAE 1 | 6 | 505X535X515 | 1 Group Head 1 Hot water outlet 1 Steam wand | 2900 | 220/50Hz/1pH | 44 |
| Tanya SAE 2 | 10.5 | 715X535X515 | 2 Group Head 1 Hot water outlet 1 Steam wand | 3600 | 440/50Hz/3pH | 55 |

TECHNICAL FEATURES

- Available from 1 to 3 groups
- Body with thermoplastic composite side panels.
- Built-in motor pump
- Steel boiler and independent pumps
- Electronic Temperature control of the boiler and coffee groups
- Pilot light indicating the water level in the boiler.
- Volumetric dosing (single or double shot)
- Automatic water refills (A. W. R.)



COLOURS

Body

Details



☐ ————— ☐
COFFEE MACHINE
SEMI-AUTOMATIC
☐ ————— ☐



Greta



SCAN ME

MADE IN ITALY

Astoria
Think espresso

Greta



TECHNICAL DESCRIPTION

| MODEL | BOILER CAPACITY (Ltrs) | DIMENSIONS (WxDxH)MM | EQUIPPED WITH | POWER (Watts/Hrs) | VOLTAGE | WEIGHT (Kg) |
|-------------|------------------------|----------------------|--|-------------------|--------------|-------------|
| Greta SAE 1 | 2 | 395X545X511 | 1 Group Head 1 Hot water outlet 1 Steam wand | 1400 | 220/50Hz/1pH | 38 |

TECHNICAL FEATURES

- Vibrating pump with 4L tank
- Boiler with automatic loading
- Pressure switch for boiler temperature control
- Thermo-syphon unit with pre-infusion
- Raised groups with flap rack
- Volumetric dosing (single or double shot)
- Motor-driven internal pump



COLOURS

Red

Stainless
Steel



KANTEEN INDIA EQUIPMENTS CO.

CB-59, Sector 1, Salt Lake City, Kolkata 700064, WB, India

Customer Care: +91-8100-777-000

E-mail: sales@kanteenindia.com | service@kanteenindia.com

Website: www.kanteenindia.com



WANT TO KNOW MORE?
SCAN HERE!



Fully Automatic Espresso Machines





Melitta® Cafina® CT8

Fast and reliable.

For large-scale requirements.

Made in Switzerland.

OPTIONS

| | |
|--------------------------------------|---|
| Second grinder | ○ |
| Hot water outlet | |
| Separate hot water outlet | ○ |
| Steam wand | ○ |
| Milk system | ○ |
| Integrated cocoa/instant module | ○ |
| Container discharge | ○ |
| Lockable bean containers | ○ |
| Fixed water connection | |
| Water tank connection | ○ |
| ACS (Automatic Coffeequality System) | |
| VPS (Variable Pressure System) | |
| CIP (Clean in Place) | |
| HACCP-certified | |
| Touchscreen-display | |
| ADD-ON MODULES | |
| Cup warmer | ○ |
| Milk cooler (9l) | ○ |
| Milk cooler underneath | ○ |
| Under-table cooler | ○ |
| Payment systems | ○ |



○ = Standard
○ = Optional

HOURLY PERFORMANCE IN CUPS*:

| | |
|---------------------|----------|
| Coffee & Café Crème | 200 |
| Cappuccino | 200 |
| Espresso | 250 |
| Cocoa | 80 |
| Hot water | 40 Liter |

* = (Depending on model, beverage and vessel size)

TECHNICAL SPECIFICATIONS

Connected values:
400 Volt / 6.8 KW

DIMENSIONS

Dimensions (WxDxH):
350 x 650 x 810 mm



USE OUR APPTO CALCULATE THE ECONOMIC EFFICIENCY OF THE MELITTA® CAFINA® CT8!

The Smart Calculator can tell you how quickly our Melitta® Cafina® CT8 pays off.



Melitta® Cafina® XT6
Coffee perfection in every cup.
Made in Switzerland.

TECHNICAL DATA

MILK FROTH SYSTEM

Dispenses hot milk, cold milk, hot foam, cold foam
(adjustments in temperature and consistency can be made in each case)

USER INTERFACE

8,4" Touch screen (projective-capacitive)
600 × 800 pixels, behind glass, 3 mm thick, thermally hardened

STANDARD EQUIPMENT

Brewing unit, stainless steel precision casting
Net weight max. 20 g
Contact pressure: Max. 1000 N, can be set individually for each product
ACS® (Automatic Coffee System)
VPS® (Variable Pressure System)
CIP® (Clean in Place)
USB interface (copy and paste recipe details)

ATTACHMENTS

MILK COOLER MC

Contents: 5 L
Dimensions (W × H × D): 180 × 580 × 580 mm

CUP WARMER CW

Contents: 80 - 120 cups
Dimensions (W × H × D): 300 × 580 × 580 mm

HOURLY PERFORMANCE IN CUPS

(depending on beverage and cup size)

| | | | | | |
|----------------------|-----|------------|-----|-----------|--------------|
| Coffee, Coffee White | 150 | Cappuccino | 130 | Hot Water | 20-25 liters |
| Espresso | 170 | Cocoa | 80 | Steam | continuous |



USE OUR APP TO CALCULATE THE ECONOMIC EFFICIENCY OF THE MELITTA® CAFINA® XT6!

The Smart Calculator can tell you how quickly our Melitta® Cafina® XT6 pays off.



Melitta[®] Cafina[®] XT5

For the digital generation.



HOURLY OUTPUT IN CUPS*:

Coffee & Caffi Crfame 100
Cappuccino 90
Espresso 150
Hot chocolate 80
Hot water 25 litres

* = (depending on the model, drink and container size)

TECHNICAL DATA

Connected loads:
230 Volt / 2.6 KW

DIMENSIONS

Dimensions (W x D x H:)
300 x 580 x 715 mm

OPTIONS

| | |
|-----------------------------------|---|
| Second grinder | o |
| Hot water output | |
| Separate hot water nozzle | o |
| Steam lance | o |
| Milk system | o |
| Hot chocolate/instant/milk powder | o |
| Container discharge | o |
| Lockable coffee bean container | o |
| Fixed water connection | |
| Operation via water container | o |
| VPS [®] | |
| CIP [®] | |
| HACCP | |

ACCESSORY EQUIPMENT

| | |
|-------------------------|---|
| Milk cooler (5 l) | o |
| Milk cooler large (11l) | o |
| Under-table cooler | o |
| Milk cooler/cup warmer | o |
| Payment system | o |
| Cup warmer | o |

= Standard feature o = optional

CALCULATE THE EFFICIENCY OF THE MELITTA[®] CAFINA[®] XT5 WITH OUR APP!

Use our Smart calculator to work out how quickly the Melitta[®] Cafina[®] XT5 pays for itself.



Melitta® Cafina® XT4

For an introduction
to the professional class.



| OPTIONS | |
|--------------------------------|---|
| 2nd grinder | ○ |
| Hot water output | |
| Separate hot water nozzle | ○ |
| Steam lance | ○ |
| Milk system | ○ |
| Cocoa/instant/milk powder | ○ |
| Container discharge | ○ |
| Lockable coffee bean container | ○ |
| Fixed water connection | |
| Fixed water connection | ○ |
| VPS | |
| CIP | |
| HACCP | |
| ADD-ON MODULES | |
| Milk cooler (5 l) | ○ |
| Large milk cooler (11 l) | ○ |
| Milk cooler underneath | ○ |
| Milk cooler/cup warmer | ○ |
| Payment systems | ○ |
| Cup warmer | ○ |

= Standard

○ = Optional

HOURLY OUTPUT IN CUPS*:

| | |
|---------------------|-----------|
| Coffee & Café Crème | 100 |
| Cappuccino | 90 |
| Espresso | 150 |
| Cocoa | 80 |
| Hot water | 20 litres |

* = (depending on the model, drink and container size)

TECHNICAL DATA

Connected loads:
230V / 2.6 kW

DIMENSIONS

Dimensions (W x D x H):
300 x 580 x 715 mm

CALCULATE THE EFFICIENCY OF THE MELITTA® CAFINA® XT4 WITH OUR APP!

Use our Smart calculator to work out how quickly the Melitta® Cafina® XT4 pays for itself.



KALEA PLUS

SLEEK DESIGN,
A COMPACT FOOTPRINT
AND HIGH PERFORMANCE



N&W AND NECTA: A LONG HISTORY OF TECHNOLOGICAL EXCELLENCE.

The origins of N&W's success within the Ho.Re.Ca. marketplace date back to the late 60s, when Zanussi Grandi Impianti (later acquired by the Swedish Group Electrolux) launched a range of automatic machines and coffee dispensers that immediately won acclaim, thanks to their performance excellence and design innovation.

*At the end of the 90s, Zanussi leaves Electrolux, is renamed Necta Vending Solutions and merges with Wittenborg, giving birth to **N&W Group, world leader in the vending sector.***

The Necta brand is the trademark of the super automatic equipment manufactured in Italy for the Ho.Re.Ca. market. It is synonymous with the Italian coffee culture, drinks quality and variety, cutting-edge technology and constant commitment to meeting the multiple needs of the Ho.Re.Ca. marketplace.

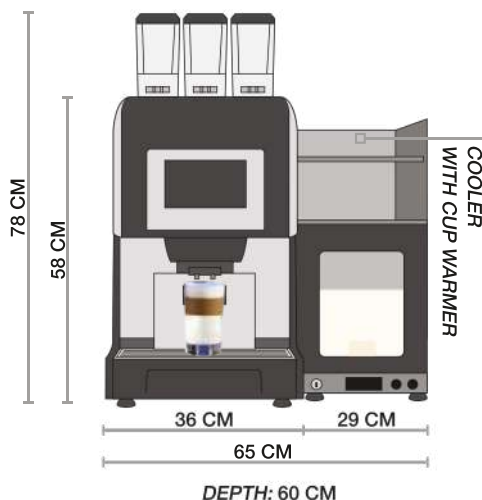

TECHNICAL DATA SHEET

| MODEL | KALEA ES + 1 INSTANT + FRESH MILK | KALEA ES + 2 INSTANT + FRESH MILK | KALEA ES + 2 INSTANT |
|-------------------------------|-----------------------------------|-----------------------------------|----------------------|
| RECOMMENDED DAILY DRINKS | 200 | 200 | 200 |
| BREWER CAPACITY | 7-16 g | 7-16 g | 7-16 g |
| SELF SETTING REG. OF GRINDING | AS OPTION | AS OPTION | AS OPTION |
| HOT WATER WAND | AS OPTION | AS OPTION | AS OPTION |
| CAPPUCCINATORE | YES | YES | NO |
| No. BOILERS | 2 | 2 | 1 |
| COFFEE BEANS HOPPER CAPACITY | 2 x 1.2 kg | 1 x 1.2 kg | 1 x 1.2 kg |
| SOLUBLE CANISTER CAPACITY | 1.5 L | 2 x 1.5 L | 2 x 1.5 L |

3G connectivity embedded for N&W cloud platform



Dr. coffee

F11

F11 COFFEE MACHINE

| | | |
|----------------------------|----------------|--------|
| Advised daily output | 100 cups | |
| Hourly output | Single | Double |
| Espresso | 70 | 100 |
| Regular Coffee | 50 | 60 |
| Cappuccino | 50 | 60 |
| Hourly hot water output | 15L | |
| Water tank capacity | 6L | |
| Beans hopper capacity | Approx. 1200 g | |
| Grounds container capacity | Approx. 30 Pcs | |

F11 SPECIFICATIONS

| | |
|---|-------------------------------------|
| Coffee machine power supply and rated power | 220-240V 50/60Hz 1.5-1.7KW |
| Fridge and cup warmer rack power supply and rated power | 220-240V 50/60Hz 40-45W |
| Plumbing type | G3/4' 150 cm flexible metal tube |
| Water pressure range | 80-800KPa (0.8-8Bar) |
| Coffee machine dimension (W*D*H) | 27+5 * 47.5 * 56.3 cm |
| Fridge Dimension (W*D*H) | 20 * 25 * 35 cm |
| Weight (coffee machine / the fridge) | 15 kg / 3 kg |

F11 series are small in size but big on flavour, with innovative fresh brewing technology. These stylish compact machines deliver a range of high quality, rich tasting coffee that easily rival traditional bar machines you would find in many coffee shops. With their compact size and elegant looks, these machines compliment a variety of environments such as small offices, meeting rooms and even at home on kitchen worktops.

GAGGIA

ACCADEMIA



Your professional barista.

- GROUND COFFEE OPTION
- REMOVABLE BREWING UNIT
- AUTO-CAPPUCCINO SYSTEM
- ONE-TOUCH BEVERAGE SELECTION
- PROGRAMMABLE DISPENSING SYSTEM
- RAPID STEAM SYSTEM
- CERAMIC GRINDER

TECHNICAL FEATURES

| | |
|-------------------------------------|------------------------------------|
| Power supply | 230V 50Hz 1400W 120V 60Hz 1250W |
| Stand-by energy consumption | < 1W |
| Class A | |
| Pump pressure | 15 bar |
| Brewing group | Removable |
| Interface | Electronic / LED |
| Beverages and maintenance menu | |
| Indicator lights | |
| Boiler | Stainless steel |
| Water tank | Removable |
| Water tank capacity | 1,2 l |
| Coffee beans container capacity | 250 g |
| Ceramic coffee grinder | |
| Grind regulator | 5 selections |
| Gaggia Adapting System | |
| Ground coffee per cup | 7 - 10,5 g |
| Optidose | |
| Pre-ground coffee option | |
| Pre-brewing | |
| Espresso plus system ESP | |
| Rapidsteam | |
| Waste coffee grounds container | Removable |
| Coffee grounds container capacity | 8 |
| Coffee delivery | 1 or 2 coffee simultaneously |
| Hot water and steam output | |
| Capuccino accessory | S/S Pannarello frother |
| Auto-cappuccino system | |
| External integrated milk jar | |
| Programmable coffee quantity in cup | |
| Adjustable dispensing head | |
| Cup plate | |
| Size in cm (L x H x D) | 25.6 x 31.5 x 44.7 |
| Weight | 8,5 kg |
| Front panel finish | Stainless steel |
| Bodywork | ABS |
| Available | Silver, black |
| Water filter | Optional |
| Coffee circuit rinsing | Automatic |
| Descaling cycle | Manual with warning |
| Accessories | Lubricant, measuring spoon |

HIGHLIGHTS & FEATURES

GROUND COFFEE OPTION

This allows you to brew a different blend of coffee without changing the beans but using the ground coffee selected.

ONE-TOUCH BEVERAGE SELECTION

With the integrated automatic milk frother, you can prepare your favourite coffee and milk specialties at the touch of a button.

PROGRAMMABLE DISPENSING SYSTEM

Programme the settings available for each kind of beverage on your electronic control panel for the ultimate in personalised your coffee and milk specialties.

AUTO-CAPPUCCINO SYSTEM

Thanks to the external milk carafe, it only take seconds to deliver frothing milk directly to your cup.

EFFICIENT CUP WARMER

An active heating element beneath the plate heats the cups efficiently ensuring hotter espressos.

ESPRESSO PLUS SYSTEM

This feature allows you to adjust the body and aroma of your coffee to suit your taste, while maintaining a perfect crema.

GAGGIA Babila



Gaggia GAGGIA
Babila
Super-automatic
espresso machine

- Brews 7 coffee varieties
- Integrated milk jug & frother
- Steel/Silver
- 15-step adjustable grinder

RI9700/64

JUST PRESS A BUTTON TO ENJOY A CREAMY CAPPUCCINO

CAPPUCCINO, CAFFÈ MACCHIATO AND MUCH MORE

GAGGIA Babila makes espresso in keeping with the finest Italian tradition in just a few seconds directly from freshly ground coffee beans, cup after cup, with the simple press of a button.



Advanced technology designed for coffee perfection

- Delicious hot Cappuccino and Latte Macchiato at one touch
- Extract maximum flavor with the 100% ceramic grinders

A variety of coffees customized to your taste

- A multitude of specialty coffees at the touch of a button
- The strength selection remembers just how strong you like it
- Fine-tune the coffee's richness with 15 grinder settings
- Enjoy a crema layer as you like it with a twist of a knob
- Refine the coffee taste by adjusting the pre-brewing time

High comfort is part of the experience

- Proven hygiene with the patented steam cleaning carafe
- Up to 5000 cups* without descaling with AquaClean filter
- Cutting-edge design with stainless steel finishing
- The fully removable brewing group can be cleaned in no time

Technical specifications

- Brewing time one cup: 45 (espresso) to 100 (long coffee) sec
- Capacity bean container: 300 gr
- Capacity milk carafe: 500 L
- Capacity waste container: up to 11 servings
- Capacity water tank: 1.5 L
- Cord length: 0.8 m
- Frequency: 50 Hz
- Max. cup height: 150 mm
- Pump pressure: 15 bar
- Voltage: 230 V
- Water boilers: 2 (instant steam)

Weight and dimensions

- Dimensions of product (WxDxH): 245 x 420 x 360 mm
- Weight of product: 13 kg

A new vision of design.



TECHNICAL SPECIFICATIONS

Technical data

**Royal
OTC**

Tusvduvsbm tqfdj<dbujpot

| | |
|------------------------|--------------------|
| Dimensions (w x h x d) | 280 x 398 x 460 mm |
| Weight | 10 kg |
| Colour | glossy dark grey |

Fmfduvsbm tqfdj<dbujpot

| | |
|----------------|-------------|
| Power supply | 230 V/50 Hz |
| Absorbed power | 1400 W |

Xbufs tqfdj<dbujpot

| | |
|--------------------------|----------------|
| Hydraulic system | single circuit |
| Hot water / steam nozzle | independent |

Water connections

| | |
|-------------------------|------------------|
| Water supply | independent tank |
| Water supply connection | no |

Capacities

| | |
|--------------------------|--------|
| Coffee beans container | 600 gr |
| Water tank | 2.5 l |
| Coffee grounds container | 18 |

Puifs tqfdj<dbujpot

| | |
|------------------------------------|------------------------------------|
| Cappuccinatore | yes |
| Coffee grinder | with steel conical blades |
| Grinder setting | manual, 7 levels |
| Coffee strength adjustment | manual, from 6 to 10 gr in 6 steps |
| Electronic pre-infusion | yes |
| Coffee dispenser height adjustment | yes (75-160 mm) |

| | |
|---|-----|
| Possibility to install the cappuccinatore on the right or the left side | yes |
|---|-----|

Interface

| | |
|--|-----|
| Graphic display with icons and text messages | yes |
| One touch cappuccino / latte macchiato | yes |

Highlights

- **Capacitive interface with photo-realistic icons**
- **Removable brewing unit**
- **Steel conical blades**
- **Height-adjustable dispenser**
- **Independent hot water nozzle**
- **Leading-edge electronics pre-engineered for Bluetooth connectivity**

TECHNICAL FEATURES

| PRODUCT MODEL | CADORNA PRESTIGE |
|---|--|
| Product code | RI9604 |
| HIGHLIGHTS | |
| User interface | Full colour TFT display + backlit button |
| Selectable display languages | 17 |
| Customisable user proles | 4 Proles |
| Milk/steam solution | Integrated carafe |
| Espresso tray | ✓ |
| Adjustable coffee spouts (min espresso tray-max) | ✓ 70 -155 mm |
| Cup plate | ✓ Stainless steel |
| Ceramic grinders | ✓ |
| Adjustable grinder setting | ✓ 10 Selections |
| Optiaroma (coffee strength) | ✓ 5 Selections |
| BEVERAGES VARIETY | |
| Number of pre-set beverages (steam excluded) | 14 |
| Ristretto | ✓ screen 4 |
| Espresso | ✓ screen 1 |
| Espresso lungo / caff lungo | ✓ screen 2 |
| Coffee (caf crema) | ✓ screen 1 |
| Americano | ✓ screen 2 |
| Caf cortado | ✓ screen 3 |
| Cappuccino | ✓ screen 1 |
| Cappuccino XL | ✓ screen 3 |
| Latte macchiato | ✓ screen 1 |
| Latte macchiato XL | ✓ screen 3 |
| Frothed milk | ✓ screen 4 |
| Flat white | ✓ screen 3 |
| Caf au lait (milchkafee) | ✓ screen 2 |
| Hot water | ✓ screen 2 |
| Steam | |
| BEVERAGES IN CUP QUALITY | |
| Pump pressure | 15 bar |
| Pre-brewing | ✓ |
| Ground coffee option | ✓ |
| Adjustable coffee length | ✓ |
| Adjustable coffee temperature | ✓ (3 levels) |
| Gaggia adapting system | ✓ |
| Heating element | Stainless steel boiler |
| Quick heat boiler | ✓ |
| EASE OF USE | |
| Capacity water tank | 1,5 l |
| Milk solution | Integrated milk carafe |
| Integrated milk carafe capacity | 0,6 l |
| External milk container capacity | |
| Bean container capacity | 300 g |
| Coffee pucks container capacity | 10 coffee pucks |
| Removable components | Milk carafe, water tank, coffee pucks container, drip tray, brew group |
| Dishwasher-safe items | Espresso tray, drip tray plate |
| Simultaneously brewing of 2 coffee cups | ✓ |
| MAINTENANCE | |
| Water lter compatibility | ✓ Intenza+ |
| Rinsing cycle | Automatic |
| Milk circuit cleaning cycle | Automatic |
| Descaling cycle | Automatic |
| MATERIALS, FINISHING AND DIMENSIONS | |
| Product dimensions (l x h x d) | 26 x 38 x 40 cm |
| Product weight | 9,6 kg |
| Bodywork | Black ABS |
| Front | Spray painted anthracite |
| Top | Black ABS |
| Drip tray | Black ABS/ stainless steel plate |
| Brewing head | Painted chrome |
| ENERGY CONSUMPTION | |
| Boiler | S/S boiler |
| Power supply | 230V 50Hz 1900W |
| ACCESSORIES | |
| Accessories | Grease tube, measuring spoon, Intenza+ |



Highlights

1. Integrated milk carafe
2. Espresso tray
3. New CAPPinCUP system
4. Brand new graphic interface
5. 4 customisable user proles

GAGGIA

MILANO

GAGGIA

MAGENTA

FULLY AUTOMATIC MACHINE



| PRODUCT MODEL | MAGENTA PRESTIGE | MAGENTA MILK | MAGENTA PLUS |
|--|--|--|---|
| Product code | RI8700 | RI8701 | RI8702 |
| HIGHLIGHTS | | | |
| User interface | Full colour TFT display + 8 capacitive buttons(2 backlighted buttons) | Full colour TFT display + 8 capacitive buttons(2 backlighted buttons) | Full colour TFT display + 8 capacitive buttons(2 backlighted buttons) |
| Type of graphic user interface | TFT full colour 2,4" | Tft full colour 2,4" | TFT Full colour 2,4" |
| Selectable languages | 21 Languages: IT-EN-DE-FR-ES-PT-NL-PL-RU-EL-RO-HU-DA-BL-CS-SL-LT-JP-ZH-TW-KO | 21 Languages: IT-EN-DE-FR-ES-PT-NL-PL-RU-EL-RO-HU-DA-BL-CS-SL-LT-JP-ZH-TW-KO | 21 Languages: IT-EN-DE-FR-ES-PT-NL-PL-RU-EL-RO-HU-DA-BL-CS-SL-LT-JP-ZH-TW-KO |
| Total beverages variety | Ristretto, espresso, espresso lungo, caff, americano, cappuccino, latte macchiato, caf au lait, at white, cortado, frothed milk, hot water | Ristretto, espresso, espresso lungo, caff, americano, cappuccino, caf au lait, frothed milk, hot water | Espresso, espresso lungo, caff, americano, hot water, steam |
| User proles | na | na | na |
| Memo function | ✓ | ✓ | ✓ |
| Milk/steam solution | Integrated milk carafe | CAPPinCUP+glass milk carafe | Professional S/S Steam wand |
| Adjustable coffee spouts (min/max height) | 70 (With espresso tray) /150 mm | 70 (With espresso tray) /150 mm | 70 (with espresso tray) /150 mm |
| Espresso tray | ✓ Stainless steel | ✓ Stainless steel | ✓ Stainless steel |
| Cup warmer | na | na | na |
| Cup plate | na | na | na |
| Ceramic grinders | ✓ | ✓ | ✓ |
| Adjustable grinder setting | ✓ 5 selections | ✓ 5 selections | ✓ 5 selections |
| Optiaroma (coffee strength) | ✓ 5 selections | ✓ 5 selections | ✓ 5 selections |
| Aroma lid | ✓ | ✓ | ✓ |
| BEVERAGES VARIETY | | | |
| Number of beverages (steam excluded) | 12 | 9 | 5 |
| Ristretto | ✓screen 4 | ✓screen 3 | |
| Espresso | ✓screen 1 | ✓screen 1 | ✓screen 1 |
| Espresso lungo | ✓screen 3 | ✓screen 2 | ✓screen 2 |
| Coffee (Caf Crema) | ✓screen 1 | ✓screen 1 | ✓screen 1 |
| Americano | ✓screen 2 | ✓screen 2 | ✓screen 2 |
| Caf cortado | ✓screen 4 | | |
| Cappuccino | ✓screen 1 | ✓screen 1 | |
| Latte macchiato | ✓screen 2 | | |
| Frothed milk | ✓screen 4 | ✓screen 3 | |
| Flat white | ✓screen 3 | | |
| Caf au lait (Milchkaffee) | ✓screen 3 | ✓screen 3 | |
| Hot water | ✓screen 2 | ✓screen 2 | ✓screen 2 |
| Steam | | | ✓screen 1 |
| BEVERAGES IN CUP QUALITY | | | |
| Pump pressure | 15 bar | 15 bar | 15 bar |
| Pre-brewing | ✓(not adjustable) | ✓(not adjustable) | ✓(not adjustable) |
| Ground coffee option | ✓ | ✓ | ✓ |
| Adjustable coffee length | ✓ | ✓ | ✓ |
| Adjustable water length | ✓ | ✓ | ✓ |
| Adjustable coffee temperature | ✓ | ✓ | ✓ |
| Adjustable milk length | ✓ | ✓ | ✓ |
| Gaggia adapting system | ✓ | ✓ | ✓ |
| Heating element | Stainless Steel boiler | Stainless Steel boiler | Stainless Steel boiler |
| Quick heat boiler | ✓ | ✓ | ✓ |
| EASE OF USE | | | |
| Capacity water tank | 1,8 l | 1,8 l | 1,8 l |
| Capacity milk carafe | 0,5l | 0,40l | na |
| Capacity bean container | 250 g | 250 g | 250 g |
| Capacity coffee pucks container | 15 coffee pucks | 15 coffee pucks | 15 coffee pucks |
| Removable components | Milk carafe; water tank; coffee pucks container; drip tray; brew group; espresso tray | Water tank; coffee pucks container; drip tray; brew group; espresso tray; CAPPinCUP; milk glass carafe | Water tank; coffee pucks container; drip tray; brew group; espresso tray; |
| Dishwashersafe items | Drip tray grid; espresso tray | Drip tray grid; espresso tray; CAPPinCUP | Drip tray grid; espresso tray |
| Simultaneously brewing of 2 coffee cups | ✓ | ✓ | ✓ |
| Grinder knob | Integrated in the beans container | Integrated in the beans container | Integrated in the beans container |
| MAINTENANCE | | | |
| Water filter compatibility | ✓ Intenza+ | ✓ Intenza+ | ✓ Intenza+ |
| Rinsing cycle | Automatic | Automatic | Automatic |
| Milk circuit cleaning cycle | Automatic | Automatic | Automatic |
| Descaling cycle | Automatic | Automatic | Automatic |
| MATERIALS, FINISHING AND DIMENSIONS | | | |
| Product Dimensions (L x H x D) | 225 x 360 x 435 mm | 225 x 360 x 435 mm | 225 x 360 x 435 mm |
| Product Weight | TBC | 7,7 kg | 7,6 kg |
| Bodywork | Matt black ABS | Matt black ABS | Matt black ABS |
| Front panel | Matt black ABS | Matt black ABS | Matt black ABS |
| Top | Matt black ABS | Matt black ABS | Matt black ABS |
| Drip tray | Matt black ABS + stainless steel | Matt black ABS + stainless steel | Matt black ABS + stainless steel |
| Brewing head | Matt black ABS + chromed frame | Matt black ABS + chromed frame | Matt black ABS + chromed frame |
| ENERGY CONSUMPTION | | | |
| Boiler | S/S boiler | S/S boiler | S/S boiler |
| Power supply | 230v 50hz 1900W | 230v 50hz 1900W | 230v 50hz 1900W |
| ACCESSORIES | | | |
| Accessories | Ground coffee spoon, water hardness strip, grease | Ground coffee spoon, water hardness strip, grease | Ground coffee spoon, water hardness strip, grease |

Model **NAVIGLIO MILK**
Product code **RI 8749/01**

HIGHLIGHTS

| | |
|--------------------------------|--|
| User interface | Buttons + led |
| Type of graphic user interface | Backlighted buttons |
| Milk/steam solution | CAPPinCUP & classic black plastic pannarello |
| Adjustable coffee spouts | ✓ 70 - 110 mm |
| Cup plate | ✓ |
| Ceramic grinders | ✓ |
| Optiaroma (coffee strength) | ✓ 3 Selections |
| Adjustable grinder setting | ✓ 5 Selections |

BEVERAGES VARIETY

| | |
|--------------------------------------|-----------------|
| Number of beverages (steam excluded) | 4 (4 one-touch) |
| Espresso | ✓ one-touch |
| Coffee (caf crema) | |
| Cappuccino | ✓ one-touch |
| Frothed milk | ✓ one-touch |
| Hot water | ✓ one-touch |
| Steam | ✓ |

BEVERAGES IN CUP QUALITY

| | |
|--------------------------|------------------------|
| Pump pressure | 15 bar |
| Pre-brewing | ✓ |
| Ground coffee option | n.a. |
| Adjustable coffee length | ✓ |
| Gaggia adapting system | ✓ |
| Heating element | Stainless steel boiler |
| Quick heat boiler | ✓ |

EASE OF USE

| | |
|---|--|
| Capacity water tank | 1,5 l |
| Capacity bean container | 300 g |
| Capacity coffee pucks container | 10 coffee pucks |
| Removable components | CAPPinCUP system & classic pannarello; water tank; coffee pucks container; drip tray; brew group |
| Simultaneously brewing of 2 coffee cups | ✓ |

MAINTENANCE

| | |
|-----------------------------|---------------------|
| Water lter compatibility | ✓ Intenza+ |
| Rinsing cycle | Automatic |
| Milk circuit cleaning cycle | Manual |
| Descaling cycle | Manual with warning |

MATERIALS, FINISHING AND DIMENSIONS

| | |
|--------------------------------|----------------------|
| Product dimensions (L x H x D) | 25,6 x 34 x 44 cm |
| Product weight | 9 kg |
| Bodywork | Black ABS |
| Front | Black ABS |
| Drip tray | ABS, Stainless steel |
| Brewing head | Black ABS |

ENERGY CONSUMPTION

| | |
|--------------|------------------------|
| Boiler | Stainless steel boiler |
| Power supply | 230V 50Hz 1850W |

ACCESSORIES

| | |
|-------------|---|
| Accessories | Pannarello, grease tube, grinder adjustment key |
|-------------|---|

GAGGIA

MILANO

GAGGIA NAVIGLIO

MILK



Highlights

- 1- Delightful in-cup results
- 2- Easy interface
- 3- New CAPPinCUP system



SCAN ME



COFFEE GRINDERS



SCAN ME





TOP
GRINDING
EXPERIENCE

GRINDIE

SOLO GRINDING BY WEIGHT

INTELLIGENT WEIGHING SYSTEM

DOUBLE CLUMP CRUSHER SYSTEM

TOUCH SCREEN WITH USER PROFILES

NOISE ABSORPTION SYSTEM

TECHNICAL AREA

WEIGHING SYSTEM: the only parameter that can assure you the measurement of the dose is WEIGHT. With Grindie, you set the desired dose for each portafilter just once, then the grinder will work with an accuracy of ± 0.1 gr. All human error is eliminated, and the self-learning system will maintain consistent precision over time.

AUTOMATIC RECOGNITION OF PORTAFILTER: to avoid any human error, Grindie does the job for you. You place the portafilter on the bracket and the grinder starts dispensing the pre-set dose.

Temperature control: To safeguard coffee flavours as much as possible, our machines work at a controlled temperature, avoiding overheating of ground coffee.

AUTOMATIC MICROMETRIC GRIND BURRS ADJUSTMENT: For maximum control, you can adjust the burrs by varying distance of $5 \mu\text{m}$ (0.005 mm) at a time.

USER EXPERIENCE

Every aspect of our equipment has been designed to facilitate use and avoid human error.

QUICK START: we know how boring and ineffective instruction manuals are, so we have implemented a quick guide in our machines. At the first switch-on, the essential procedures to put the coffee grinder in working condition will be indicated step by step: language choice, load cell calibration, filter tare register and user password creation.

USER PROFILE: one of the recurring problems when there are more operators is that everyone wants to adjust the machine to suit their own personal preferences. This is why we developed Grindie's firmware on 3 levels: factory, configuration and operator. Once all parameters are set, they are protected with passwords and only the password owner can make changes.

Guided procedure for cleaning: ordinary cleaning plays a fundamental role in achieving a precise and

DISCOVER SOLO

- Weighing system with **± 0.1 grams accuracy**
- Patented **anti-clumping** system
- **Automatic recognition** of 3 different portafilters in less than 1 second
- 3 different types of titanium coated burrs available
- **Guided cleaning** procedure
- Motorized micrometrical adjustment
- Temperature control
- Burrs consumption alarm
- Sound absorption system
- 3 different user profiles
- USB port for firmware update and alarm download
- Simplified maintenance
- Burrs with anti-sticking system
- Low power consumption

TECHNICAL FEATURES

PRODUCTIVITY:
7,5 15,5 Kg/h

MOTOR:
900rpm

BURRS:
Focus, Adaptive, Hybrid

BURRS MATERIAL:
Red speed
Black diamond coating

HOPPER:
1,2 Kg

DIMENSIONS:
235x235x474h mm



SCAN ME



FEATURES

New electronic features and optional IoT functionality give to barista, coffee roaster, business owner or service more control over the grinder.

- 19 LANGUAGE Control Panel with wide viewing angle
- PROGRAMMABLE single, double, and triple dose buttons
- Steps of a hundredth of a second
- Total and partial dose COUNTER
- Programmable PAUSE FUNCTION in between grinding
- MANUAL GRINDING mode
- Ability to set up a MAXIMUM DOSE CAP
- Daily grinding STATISTICS
- ALERTS on service needs, worn burrs
- Firmware UPGRADES

THE EVOLUTION OF AN ICON

A modern grinder that paid tribute to the iconic style of the 1971 Mazzer Jolly. The evolution of its design, updated with new, sleek lines and neat shapes, makes the Mazzer Super Jolly V pro a contemporary classic.

KEEP IT SAFE



Protect your coffee beans from temperature exposure and preserve your bean's fresh roasted flavor with the double fan cooling system.

HARDENED HIGH CARBON STEEL BURRS



64mm flat burrs have been re-engineered to speed up the dosing time by 20%. 100% made in Italy by Mazzer.

SAVE COFFEE



Low retention grinder to save time and coffee each time you change your settings.

CONSISTENT RESULTS



Uniform coffee grounds and consistent dosing to keep consistent results.

DURABLE AND ECO-FRIENDLY



93% of the grinder weight comes from premium materials like stainless steel, aluminum, brass, and copper, to make it not only durable but also easy to recycle and eco-friendly.

GFC Grind Flow Control System

MAXIMUM CONTROL

GFC Reduces the electrostatic charge which causes the coffee powder on tray and counter and prevents clumping.

It is composed of a removable aluminum outlet insert equipped with an easy to clean extractable wire damper to get a dynamic control over the flow of coffee throughout the chute.

IoT functionalities

BE CONNECTED

Wherever you are, be connected to your grinder on your cloud. Thanks to the internet-connectable platform data about your grinder is remotely easily accessible. You'll be able to monitor any and all of your grinders' output, keep up with maintenance needs, and improve the quality of your coffee in a scientific way using data tracked by the grinder (optional).

dimensions

colours

| | mm | inches |
|---|-----|--------|
| A | 207 | 8 ¼ |
| B | 240 | 9 ½ |
| C | 255 | 10 |
| D | 410 | 16 ¼ |
| H | 595 | 23 ½ |
| E | 210 | 8 ¼ |

 pure white

 matt black

 matt gray

 silver

 polished aluminum

 bright red

 64mm flat burrs



Super Jolly/V Up electronic

ELECTRONIC FEATURES

YOUR COFFEE SIDEKICK

New electronic features give to barista, coffee roaster, business owner or service more control over the grinder.

- TOUCH** control panel
- PROGRAMMABLE** single, double and third dose buttons
- MANUAL GRINDING** mode
- STEPS** of a hundredth of a second
- TOTAL** dose counter
- PARTIAL** dose counter
- MANUAL PAUSE** function in between grinding
- Ability to set up a **MAX TIME** per dose

Bright and colourful **TOUCH** control panel

EXCELLENT TOUCH DETECTION

Super Jolly V Up is the first in the Mazzer range to feature a bright **TOUCH CONTROL PANEL**, direct and easy to understand, with an excellent touch detection and wide viewing angle.

Tech Specs

Grinding on demand, electronic dose adjustment

| | |
|-----------------------------|--|
| Power | 350 Watt |
| Grinding adjustment | stepless micrometrical |
| Burrs | flat burrs 64mm (2 1/2 inches) (ref. 233M) |
| Grinding burrs speed | 1400 rpm (50 Hz) - 1600 rpm (60Hz) |
| Body | aluminum die casting |
| Hopper capacity | 1.1 kg (2.4 lbs) |
| Net weight | 14 kg - 31 lbs |
| Equipment features | GFC |
| Optional features | Tag holder |



SIMPLICITY OF USE

The grinder is easy to use, and has everything you need to make excellent coffee in a small to medium-sized coffee shop. The Super Jolly V Up is a streamlined sibling to the V Pro with a touch-sensitive digital interface.

MUST-HAVE FEATURES

- Universal **portafilter holder** adjustable in height
- Portafilter activated grind button** to grind hand-free
- Stepless** micrometrical grind adjustment
- Optional magnet to place a **tag** on the hopper with the name of the coffee



Grind Flow Control System

MAXIMUM CONTROL

GFC Reduces the electrostatic charge which causes the coffee powder on tray and counter and **prevents clumping**. It is composed of a **removable** aluminum outlet insert equipped with an easy to clean extractable wire damper to get a **dynamic control** over the flow of coffee throughout the chute.



RELIABLE AND ICONIC

The new Super Jolly V Up is addressed to those who look for simplicity of use without having to compromise on reliability or ergonomics. A modern grinder that paid tribute to the iconic style of the 1971 Mazzer Jolly.

HARDENED HIGH CARBON STEEL BURRS

64mm flat burrs have been re-engineered to **speed up** the dosing time by 20%. 100% made in Italy by Mazzer.

SAVE COFFEE

Low retention grinder to **save time and coffee** each time you change your settings.

CONSISTENT RESULTS

Uniform coffee grounds and consistent dosing to keep consistent results.

DURABLE AND ECO-FRIENDLY

93% of the grinder weight comes from **premium materials** like stainless steel, aluminum, brass, and copper, to make it not only durable but also easy to recycle and eco-friendly.

| dimensions | | colours | |
|------------|-----|---------|-------------------|
| | mm | inches | |
| A | 207 | 8 1/4 | pure white |
| B | 240 | 9 1/2 | matt black |
| C | 255 | 10 | matt gray |
| D | 410 | 16 1/4 | silver |
| H | 595 | 23 3/4 | polished aluminum |
| E | 210 | 8 1/4 | bright red |

64mm flat burrs

About MAZZER

Mazzer is a leading company for the manufacture of coffee grinders, grinder-dosers and accessories. Its products are distributed in 90 countries worldwide and are well known for quality, reliability and design. The company is present throughout the entire technological process and the reliability of its components is internationally appreciated.

Super Jolly Electronic

Electronic grinder-doser with flat blades suitable for medium consumption.

Stepless micrometrical grinding adjustment.

On-demand grinding with electronic dose adjustment.

Single and double dose with independent adjustment.

Digital display with shot counter.

Hand tamper and support for tamping are included.

Available in single phase version only.

TECHNICAL FEATURES

| | |
|-----------------------|--|
| Power | 350 Watt |
| Grinding blades | Flat Ø 64 mm - 2½ inches (ref. 33M) |
| Grinding blade speed | 1400 r.p.m. (50 Hz) 1600 r.p.m. (60 Hz) |
| Coffee-bean container | 1,2 Kg (2,7 lbs) |
| Net weight | 14 Kg (31 lbs) |

SUPER JOLLY ELECTRONIC



A SERIES - GRIND ON DEMAND



New Interface

Easy setting and temperature and humidity check



Unbreakable Hopper

It is made of polycarbonate and is sturdy and durable

1.6kg ←



Easy dialing throttle

It is possible to adjust the grinding degree easily and comfortably by dialing method



Temperature and humidity display function

As well as setting, you can store beans in its best condition.

Grinding

Anti-statical

It's anti-static design, the ground coffee is not scatter



| | |
|--------|-------------------|
| Volt | 220~240V, 50~60Hz |
| Motor | 1,400 RPM |
| Power | 350W |
| Weight | 13.5kg |
| Size | 210 x 360 x 620mm |
| Burr | 64mm burr |
| Hopper | 1,600g |



A Series Mini ED Black



Specification

| Dimension | Electrical | Capacity |
|----------------|-----------------|------------------------|
| Width: 170 mm | Voltage: 230 V | Hopper – 600 g |
| Height: 460 mm | Freq.: 50/60 Hz | Grinding disc – 64 mm |
| Depth: 290 mm | Power: 350 W | RPM – 1400rpm |
| Weight: 10 kg | | Output Per Hour – 12kg |
| | | |

COFFEE LINE

**MXD
Xtreme**
ON DEMAND
GRINDERS

MXD XtremeDIGITAL

Flat grinding blades Ø 75 mm
titanium
Power 520 W



FEATURES

Three programmable doses
Manual dosing
Flat grinding blades Ø75 mm titanium
Hopper capacity 1.4 kg
Dosing counter
Stepless adjustment system

DIMENSIONS

Dimensions 230 x 370 x h600 mm
Net weight 12.8 kg

POWER

Grinding output 4 g/s
Power 520 W
Motor 1400 rpm (50 Hz)
1680 rpm (60 Hz)

COLORS

C05 white C10 grey
 C11 dark grey C18 black
 C24 red C83 chrome (opt)

OPTIONAL

Stainless steel tamper
Filter-holder support



Titanium grinding blade



Stainless steel tamper



Filter-holder support



MI40 Touch

On demand grinder

MI40 Toch

Grinding blades Ø 65 mm

Power 480W



Display Touch Screen 3,533



| |
|--------------------------------|
| Interface with icons. |
| Customization of doses. |
| Customization of interface |
| Three working modes to choose: |
| Estándar |
| Push and grind |
| Barista |

MI40 Touch

On demand grinder

Features:

High Precision Grinding: Equipped with 65mm flat burrs for consistent and precise grinding, delivering uniform coffee grounds for optimal extraction.

Stepless Adjustment: Offers stepless micrometric adjustment for precise control over grind size, catering to various brewing methods.

Touch Screen Interface: Features an intuitive touch screen display for easy adjustment and monitoring of the grinding process.

Large Capacity Hopper: The spacious hopper holds up to 1.4 kg of coffee beans, making it ideal for high-demand environments.

Durable Construction: Built with high-quality materials, including a robust motor and sturdy housing, ensuring long-lasting performance.

Quiet Operation: Designed to operate quietly, making it suitable for noise-sensitive environments.



CHARACTERISTICS

| | |
|--|--|
| Four programmable doses | |
| Grinding blades | Ø 65 mm, Flat |
| Power | 480 W |
| Motor | 1400 rpm (50 Hz) / 1680 rpm (60 Hz) |
| Dimensions | 194 x 307 x 560 mm |
| Hopper capacity | 1,2 Kg |
| Production | 2,6 - 3,3 g/s |
| Net weight | 8,9 Kg |
| Display Touch Screen 3,5 ^o with new HMI | Hands-free fork |
| Grind adjustment ring with zero grind setting | Metal fork with anti-vibration coating |
| Stepless adjustment system | Air intakes in the base for forced suction |
| Speed of service | Adjustable cooling fan |

About MAZZER

Mazzer is a leading company for the manufacture of coffee grinders, grinder-dosers and accessories. Its products are distributed in 90 countries worldwide and are well known for quality, reliability and design. The company is present throughout the entire technological process and the reliability of its components is internationally appreciated.

Available in the following versions:

- with manual switch
- with time switch
- automatic with start every 12 doses and stop when the ground coffee doser is full

TECHNICAL FEATURES:

| | |
|--|--|
| Power | 350 Watt |
| Grinding Blades | Ø 64 mm (2½ inches) |
| (single phase ref. 33M - three phase ref. 33T) | |
| Grinding blade speed | 1400 (50 Hz) r.p.m. 1600 (60 Hz) r.p.m. |
| Coffee-bean container capacity | 1,2 Kg (2,7 lbs) |
| Ground coffee container capacity | 280 g (0,6 lbs) |
| Dose adjustment | 5,5-8 g (0,19 - 0,28 oz) |
| Net weight | 14 Kg (31 lbs) |



| | mm | inches |
|---|-----|--------|
| A | 122 | 1 3/4 |
| B | 343 | 10 3/8 |
| C | 340 | 10 3/8 |
| D | 450 | 14 1/2 |
| H | 610 | 19 3/4 |
| Ø | 64 | 2 1/2 |



COLOURS

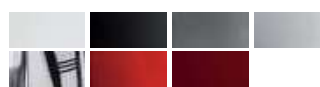

A SERIES MANUAL

Specification

| Dimension | Electrical | Capacity |
|----------------|-----------------|-----------------------|
| Width: 210 mm | Voltage: 230 V | Hopper – 1600 g |
| Height: 620 mm | Freq.: 50/60 Hz | Grinding disc – 64 mm |
| Depth: 360 mm | Power: 350W | RPM – 1400rpm |
| Weight: 13.5kg | | Output Per Hour 4kg |

Grinder- dozer with flat blades suitable for medium consumption. Stepless micrometrical grinding adjustment.



Mazzer ZM



The ZM features flat **BURRS** specifically designed and tested to grind for filter coffee (151F) or espresso (151B). 151G for filter available as spare part

<0.45

The **LOWEST** coffee **RETENTION**, <0.45g



DIGITAL GRIND ADJUSTMENT

Control the distance between the burrs in **MICRONS** so the grind setting is understandable, accurate, and repeatable.



Electronic **TRUE ZERO CALIBRATION** ensures that the ZM grind settings are identical from grinder to grinder, café to café.



Keep coffee grounds safe from temperature exposure preserving maximum aroma. **DOUBLE FAN COOLING SYSTEM** with electronic controls. **LOW RPM** (900 – 1050Hz) with excellent grinding speed



ON-DEMAND dosing capability – adjustable grinding time



EASY TO CLEAN grinding chamber



SECURE double safety switch



Patented **LOCKABLE CANISTER** to keep coffee grounds from getting on the counter



Smart Knob to navigate the menu
Manopola di navigazione

Alerts on service needs and statistics
Notifiche di servizio, avvisi cambio macine e statistiche

Customizable welcome message
Messaggio di benvenuto personalizzabile

Can record up to 20 grind settings, with customized names for each setting
20 posizioni di macinatura memorizzabili con precisione micrometrica e personalizzabili con nome

4 programmable buttons for quick recipe recall
4 tasti programmabili per richiamare velocemente le posizioni di macinatura preferite



Flipping display

The digital display flips to the side to allow easy access to the grinding chamber for cleaning and burr replacement
Facile accesso alla camera di macinatura per pulizia e cambio macine



SCAN ME

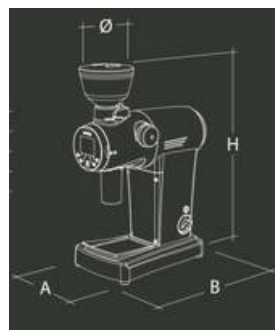

| | mm | inches |
|---|-----|--------|
| A | 245 | 9 ¾ |
| B | 430 | 17 |
| Ø | 160 | 6 ¼ |
| H | 645 | 25 ½ |

Colours
MattBlack
PureWhite
Silver



FEATURES

TAKE A JOURNEY THROUGH YOUR COFFEE

Mazzer Philos is a **PREMIUM SINGLE DOSE FLAT BURR GRINDER** designed to help you get the most out of your coffee. Its elegant design, accurate machining, and superior materials make it the ideal choice for demanding baristas looking for **QUALITY IN SMALL SPACES**. It is suitable for **ALL EXTRACTION METHODS**, from espresso to batch brew.



OPTIMIZED WORKFLOW, EFFORTLESS MAINTENANCE

- The grinder is designed to **LOWER ELECTROSTATIC CHARGES** in the ground coffee, keeping the counter **clean from coffee dust**.
- Access the **GRINDING CHAMBER** to clean or change the burrs without tools and **WITHOUT LOSING THE GRIND SETTING**, as the adjustment ring is located on the back. This position also prevents any unintended collar movement.
- **STRONG NEODYMIUM MAGNETS** hold the stainless steel dosing cup (which fits 58mm portafilters) and the dose-finisher in place.
- The **CABLE CAN BE SHORTENED** and stored inside the grinder to keep the counter neat and tidy.

SMALL, SILENT AND SAFE

- Philos is compact and takes up little counter space, making it easy to fit into **TIGHT SPACES**.
- Tight tolerances, low frequencies and a vibration-damping system keep the Philos **QUIET AND STABLE**.
- Electronic and mechanic security systems keep the user **SAFE** even when the hopper is off.
- The components that come into contact with coffee are **FOOD-SAFE**.

BEAUTIFUL INSIDE AND OUT

Philos' **NEAT DESIGN**, inspired by the sleek lines of Mazzer ZM, works well on any countertop. The **ASYNCHRONOUS MOTOR** and precise component machining provide **DURABILITY** over time and **HIGH RELIABILITY**. **PREMIUM MATERIALS** like stainless steel, brass and anodized aluminum make the 12.5 kg grinder not only reliable, but also **EASY TO RECYCLE** and **SUSTAINABLE**.

STEPPED OR STEPLESS: IT'S UP TO YOU

Easily switch from stepped to stepless mode with a **simple procedure**.

- **STEPPED MODE**: with single-step increments as small as **6 microns**, the graduated adjustment ring covers **all brewing methods**, from espresso to batch brew. This makes grind adjustment a breeze, ensuring **repeatability** in your recipes.
- **STEPLESS MODE**: if you are looking for **infinite settings** to dial in the perfect shot, Philos can be converted into a stepless grinder.

ZERO RETENTION

Philos allows you to switch seamlessly from one origin or brewing method to another without wasting coffee. The grinder is designed and tested to avoid retention and contaminations of coffees. The handy **DOSE-FINISHER** collects any ground coffee residue while cleaning the chute. When not in use, it can be stored in its dedicated slot behind the front plate.



Tech Specs

| | |
|----------------------|--|
| Power | 400 Watt |
| Grinding adjustment | step and stepless micrometrical |
| Burrs | stainless steel flat burrs 64mm (3 1/4 in) for filter or espresso (I200D or I189D) |
| Grinding burrs speed | 1400 rpm (50 Hz) - 1600 rpm (60Hz) |
| Body | anodized aluminum |
| Hopper capacity | 60 g (0.13 lbs) |
| Net weight | 12.5 kg (27.5 lbs) |
| Canister | capacity 60 g / for ø58 portafilters |
| Optional features | canister for ø53 portafilters |

| dimensions | | colours | |
|----------------|------------------------|---------|----------------|
| | mm | inches | |
| W | 153 | 6 | |
| H | 361 | 14 1/4 | |
| D | 351 | 14 | |
| | 64mm flat burrs | | anodized black |
| certifications | | | |
| | | | |
| | | | |
| | | | |





Kony/S^g

ACCURATE GRINDING BY WEIGHT



Grinding on demand, electronic dose adjustment, ventilation with electronic control

| | |
|-----------------------------|--|
| Power | 450 Watt |
| Grinding adjustment | stepless micrometrical |
| Burrs | conical burrs 63 mm - 2 ½ inches (ref. 191C) |
| Grinding burrs speed | 420 rpm (50Hz) - 500 rpm (60Hz) |
| Body | aluminum die casting |
| Hopper capacity | 1.3 kg (2.9 lbs) |
| Net weight | 22 kg (48.5 lbs) |
| Equipment features: | IoT, Tag holder, GFC Kit |
| Optional: | hand tamper in aluminum with support base |



Kony Sg features a professional-grade built-in scale. The load cell is accurate, repeatable, and can be set to a hundredth of a gram to weigh each dose, offering maximum precision and consistent results.

2.4" COLOR TFT DISPLAY with excellent viewing angle, 19 languages

3 PROGRAMMABLE DOSES by weight or by time with setting accuracy to the hundredth of a gram / second. Additional manual grinding mode.

WEIGHT RECALIBRATION procedure

Ability to **LIMIT THE NUMBER OF GRINDABLE DOSES** according to the coffee stock

AUTOMATIC DOSE PAUSE upon removal of the portafilter to settle down the powder

CUSTOMIZABLE DISPLAY with logo and color theme

ALERTS on service needs, worn burrs, empty hopper

DAILY GRINDING STATISTICS



Low RPM conical burr grinder with BUILT-IN LOAD CELL DESIGNED TO DELIVER

This is the ideal choice for medium volume cafes. Silent and with low coffee retention, it helps to get full bodied well balanced extractions.

GFC

Keep grounds from getting on the counter (**ELECTROSTATIC CHARGE REDUCTION**) while getting **UNIFORM COFFEE GROUNDS** in your portafilter with the innovative GFC System. GFC - Grind Flow Control consists of a removable aluminum outlet insert equipped with two dampers (Hybrid and AntiClumping)



No loss of grind settings with **EASY TO CLEAN** grinding chamber



User friendly **MEMORY TRACK** system to index grind setting. Wide grinding adjustment range



DOUBLE FAN cooling system



ADJUSTABLE PORTAFILTER HOLDER. Grind hands-free and consistently center the flow of grinds in your basket



TAG HOLDER
use the magnet to place a tag on the hopper with the name of the coffee you are serving

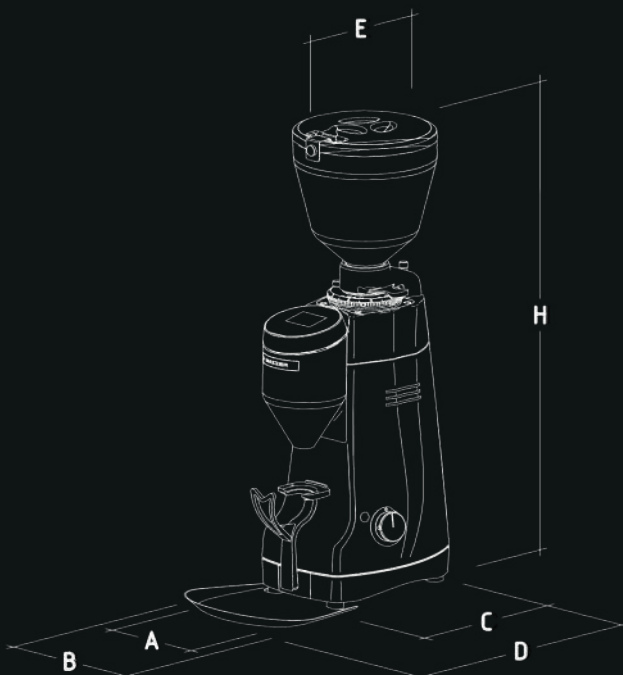

dimensions

| | mm | inches |
|---|-----|--------|
| A | 208 | 8 1/4 |
| B | 240 | 9 1/2 |
| C | 264 | 10 1/2 |
| D | 413 | 16 1/4 |
| H | 695 | 27 1/2 |
| E | 210 | 8 1/4 |

colours

| | |
|--|---|
| | pure white bianco neve |
| | matt black nero opaco |
| | matt gray grigio opaco |
| | silver grigio chiaro |
| | polished aluminum alluminio lucidato |
| | bright red rosso ciliegia |



63mm
conical burrs

certifications



Stepless micrometrical grind adjustment
Sistema di regolazione macinatura micrometrica continua



SECURITY FEATURES
Sistemi di protezione

Drogheria Mcd4

Our Plus
Stepless Micrometric Regulation System (patented by Eureka)

Easy Setting System

"High Speed" Maintenance

Blow Up System

All-Purpose grinder

New coffee channel with bag holder

Aluminium body and base



Technical specifications

| | |
|-------------------------------|--|
| BURRS | VARIOUS |
| Type flat | Typology Manual |
| Diameter 65 - 75 - 85 mm | Stepless micrometric adjustment Yes |
| Material Hardened steel | Bean hopper capacity 1,4 kg |
| | Productivity (g/s) |
| ENGINE | 3 - 4 Espresso 4 - 5 Brew (macine 65 mm) |
| Traction Direct | 5,5 - 6,5 Espresso 7,5 - 8,5 Brew (macine 75 mm) |
| Rpm | 7 - 8 Espresso 10 - 11 Brew (macine 85 mm) |
| 1290 (65 mm burrs) | DIMENSIONS |
| 1430 (75 mm burrs) | Height 645 mm |
| 1430 (85 mm burrs) | Width 184 mm |
| Power absorbed | Depth 267 mm |
| 450 watt (65 mm burrs) | Weight |
| 750 watt (75 mm burrs) | 11,5 kg (65 mm burrs) |
| 750 watt (85 mm burrs) | 14 kg (75 mm burrs) |
| Feeding Single or three-phase | 14,2 kg (85 mm burrs) |

Available Colours

standard colours

- matt black
- grey



SCAN ME



▶ FEATURES

Instant

| | |
|--------------------------------|--------------------------------------|
| Flat burrs | Ø 70 mm |
| Dimensions Standard (WxDxH) | 310×210×625 mm |
| With optional C | 310×210×550 mm |
| Net weight | 17 Kg |
| Power | 900 W |
| RPM | 1400 rpm (50 Hz) 1680 rpm (60 Hz) |

▶ COLOURS

| | |
|------------|--------------|
| C06 | Matt ivory |
| C18 | Matt black |
| C31 | Matt mustard |

▶ STANDARD

3 programmable doses, manual dosing, grinding output 6 g/s, hopper capacity 1.2 Kg, dose counter device, 3D adjustment fork

 **MACAP**[®]



A SERIES - RETAIL GRINDER



- Compact Design: mini in size, max in power
- Anti-static/Clumping grinding outlet
- Manual on Demand
- Extensive Grinding Range from Espresso to Filter Coffee
- Industrial Extruded Aluminium Body
- Italy-made Burrs with 600kg Grinding Life



Specification

| Dimension | Electrical | Capacity |
|---------------|-----------------|-------------------------|
| Width: 170mm | Voltage: 230V | Hopper - 600 g |
| Height: 460mm | Freq.: 50/60 Hz | Grinding disc - 64 mm |
| Depth: 290mm | Power: 250 W | RPM - 1400rpm |
| Weight: 9 kg | | Grinding Speed - 3g/Sec |
| | | |

TIMEMORE SCULPTOR
078s



Product Parameters

NAME :

Sculptor 078/078s TIMEMORE Electric Coffee Grinder

COLOR :

Sculptor 078/078s TIMEMORE Electric Coffee Grinder

MATERIAL :

Aluminum Alloy
Stainless Steel + PCTG

Dimensions L*W*H*(mm) :

261mm x 118mm x 294mm

Catch Cup Size :

58mm * 100.5mm





Successful cafés go beyond good coffee to create a perfect complement of confectionery and savouries that help create a winning formula. The lifeline behind a careful menu selection is often a range of equipment that is not just dependable and energy efficient but also aesthetically appealing. Presented here is a bouquet of products from Butler and Trufrost that perform tirelessly and help your cash registers moving.





CONTENTS

- Traditional Coffee Machines **6**
- Fully Automatic Coffee Machines **19**
- Milk Chillers & Cup Warmers **21**
- Coffee Beans Grinders **23**
- Coffee Accessories **25**
- Display Cases for Confectionery **30**
- Commercial Microwave Ovens **39**
- Ventless High Speed Ovens **41**
- Modular Bakery Equipment **44**
- Electric Convection Oven **48**
- Pizza Stone Ovens **51**
- Contract Grills **53**
- Fryers **56**
- Waffle Bakers **60**
- Chocolate Melter **61**
- Commercial Blenders **63**
- Drink Mixer **64**
- Professional Refrigeration **65**
- Ice Machines **66**
- Stainless Steel Furniture **67**



The best of Italian coffee

Coffee connoisseurs and many coffee lovers still fall back on traditional coffee machines for a real coffee experience. We offer traditional coffee machines from premium Italian names like Victoria Arduino, La Cimbali and Elektra that reflect the finest tradition of Italian espresso for both – popular as well as speciality cafes.

Victoria Arduino

ELEKTRA
ITALIAN ESPRESSO COFFEE MACHINES SINCE 1947

LA CIMBALI

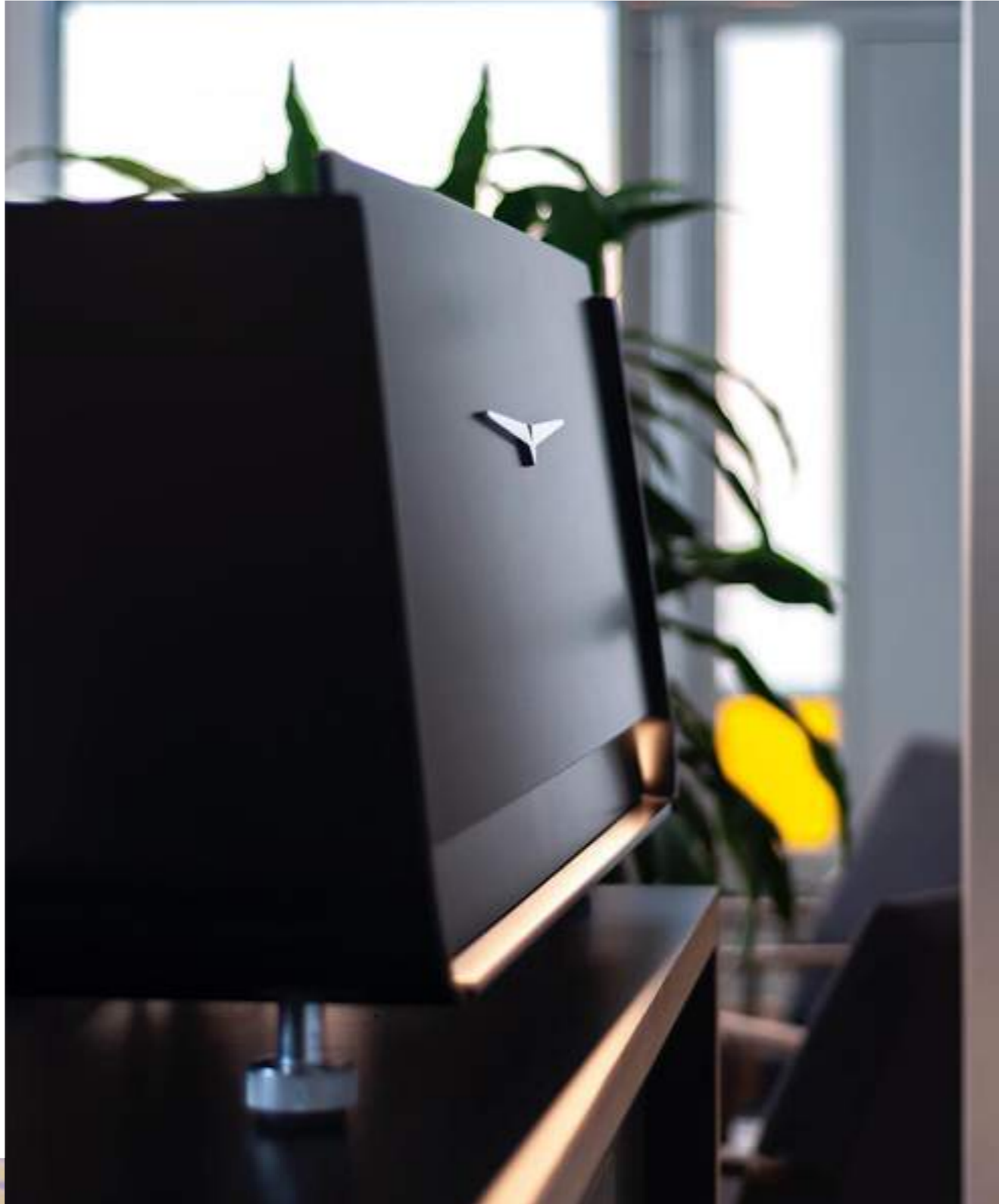

Victoria Arduino

INSPIRED BY YOUR PASSION.

Trufrost & Butler now brings Victoria Arduino coffee machines - the iconic brand behind the champs at the World Barista Championship- to India.

This marks the beginning of a new era for Indian speciality coffee and the pursuit of excellence across the coffee value chain - one inspired by your passion and your precision.

With this partnership, we reaffirm our commitment to India's rapidly growing coffee community by empowering cafés, baristas, and roasters with world-class equipment that delivers on consistency, performance, and design, backed by a strong support infrastructure.



BLACK EAGLE MAVERICK



INNOVATION INSPIRES GENIUS

Black Eagle Maverick is the coffee machine for those who want to express the most of their potential, with a strong focus on sustainability and energy saving.

Black Eagle Maverick is intelligent and sustainable, able to offer total control over temperature, infusion, steam and even the opportunity to instantaneously switch between different types of coffee.

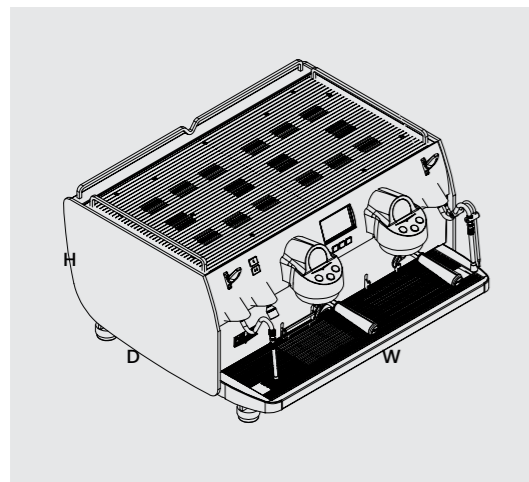

| | 2 Groups | 3 Groups |
|-----------------------------|------------------------|------------------------|
| Versions | Volumetric/gravimetric | Volumetric/gravimetric |
| Width (mm) | 806 | 1056 |
| Depth (mm) | 682 | 682 |
| Height (mm) | 426 | 426 |
| Group Height (mm) | 100 | 100 |
| Power (W) | 6800 | 8600 |
| Net Weight (Kg) | 90 | 115 |
| Insulated boiler (L) | 8 | 8 |
| Insulated coffee boiler (L) | 0,6 | 0,6 |
| Autopurge | standard | standard |
| Easycream | opt. | opt. |

TECHNOLOGIES



T3 GENIUS

An evolution from T3 technology (temperature control and stability), able to offer the same precision and control, using 37% less energy. This important result was obtained by reducing the volume of the stainless steel boilers, by optimising the weight of the group, by increasing its reactivity and precision, by improving the electronics and by using waste energy from preheating the incoming water.

TERS

The patented TERS system (Temperature Energy Recovery System) makes it possible to use the waste water for preheating the incoming water, using a process of recycling and minimisation of waste with an **8% saving** on the total consumption of the machine.

PUREBREW TECHNOLOGY

PureBrew is the technology that, along with the new patented of PureBrewCoffee, a filter coffee with unique characteristics, activated from the machine or the app with a simple switch.

GRAVITECH

A volumetric system for control and management of the coffee in the cup able to guarantee maximum consistency and repeatability of the result.

ADVANCED STEAM

A high quality dry steam delivery system at high pressure (2.1 bar) with the addition of two controls for splitting the steam between different-sized jugs.

APP

With the creation of recipes based on espresso or Pure Brew and on their sensorial profile, and with the visualisation of flow rate, the Black Eagle Maverick app is extremely simple to use and allows the barista to have total control over one or more Black Eagle Mavericks.

COLOURS

Accessories kit includes red eagle personalisation



Black



Stainless steel



Blue Stone



White



EJ EAGLE ONE



Product selected by
ADI Design Index 2020



FUTURE BEGINS

Eagle One is the coffee machine that was created to respond to the needs of the new generation of shops and chains where design, performance and sustainability make up the principal asset to provide a memorable experience to those who spend their days in the venue.

The machine represents the new way for an international clientele to spend time in the shop. People like this are, now more than ever, sensitive to a much broader concept of design that is created from experience and storytelling.

| | 2 Groups | 3 Groups |
|-----------------------------|------------|------------|
| Versions | Volumetric | Volumetric |
| Width (mm) | 758 | 988 |
| Depth (mm) | 576 | 576 |
| Height (mm) | 437 | 437 |
| Group Height (mm) | 105 | 105 |
| Power (W) | 5000 | 6500 |
| Net Weight (Kg) | 68.5 | 84 |
| Insulated boiler (L) | 7 | 7 |
| Insulated coffee boiler (L) | 0,14 | 0,14 |
| Autopurge | standard | standard |
| Easycream | opt. | opt. |

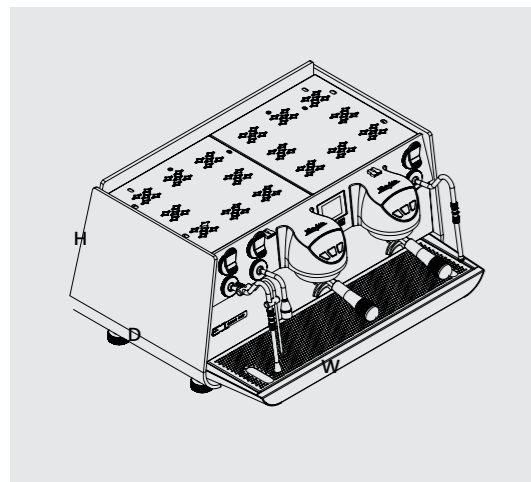

TECHNOLOGIES



NEO TECHNOLOGY

New Engine Optimization is an exclusive technology that enables high performance and improves energy efficiency. All the barista has to do is set the temperature from the display. The NEO motor uses the instantaneous heating technology that requires smaller volumes and boilers because only the water that is needed is heated.

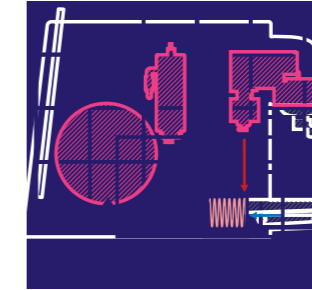

T.E.R.S.

The patented TERS system (Temperature Energy Recovery System) uses the waste water to pre-heat the incoming water, applying recycling and waste minimisation logic, with a saving of 8% on the total consumption of the machine.



EASYCREAM optional

The technological solution to obtain, every time, the same milk cream, simply and quickly. Easycream technology has a double wand that creams the milk and stops automatically as soon as the pre-set levels of temperature and milk cream have been reached. This is an extremely useful solution for speeding up the preparation of milk-based drinks, without loss of quality (optional).



VIS

VIS-Virtual Intelligent Scale is a Victoria Arduino technology developed to digitally estimate the right dose in the cup using an algorithm calculation. VIS brings improved workflow and the certainty of a great extraction making Eagle One an even better performing and smarter system.

COLOURS



Black



Stainless steel



White



Wood

EAGLE TEMPO



POETRY IN MOTION

Eagle Tempo is the professional espresso coffee machine specially designed for cafés, restaurants, roasteries, chains, pastry shops and bakeries. The new coffee machine combines the iconic brand, the elegant and distinctive design that is so characteristic of the Victoria Arduino range and high productivity performance.

Victoria Arduino thus strengthens its range with a product that has recognisable design and high productive capacity, incorporating technology that enables the business to be managed whilst saving energy and reducing waste.

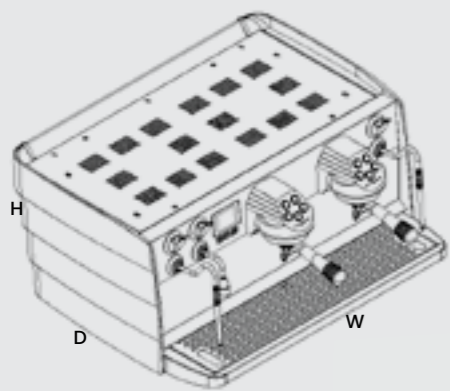

| Versions | 2 Groups | | 3 Groups | |
|-----------------------------|----------|---------------|----------|---------------|
| | NEO | Single Boiler | NEO | Single Boiler |
| Width (mm) | 825 | 825 | 825 | 825 |
| Depth (mm) | 650 | 650 | 650 | 650 |
| Height (mm) | 416 | 416 | 416 | 416 |
| Low or High groups | - | - | - | - |
| Power (W) | 6000 | 4700 | 7400 | 5200 |
| Net Weight (Kg) | 62 | 62 | 73 | 73 |
| Insulated boiler (L) | 8 | 11 | 8 | 17 |
| Insulated coffee boiler (L) | 0,14 | - | 0,14 | - |
| Autopurge | opt. | opt. | opt. | opt. |
| Easycream | opt. | opt. | opt. | opt. |

TECHNOLOGIES



NEO TECHNOLOGY

New Engine Optimization is an exclusive technology that enables high performance and improves energy efficiency. All the barista has to do is set the temperature from the display. The NEO motor uses the instantaneous heating technology that requires smaller volumes and boilers because only the water that is needed is heated.



T.E.R.S.

The patented TERS system (Temperature Energy Recovery System) uses the waste water to pre-heat the incoming water, applying recycling and waste minimisation logic, with a saving of 8% on the total consumption of the machine.

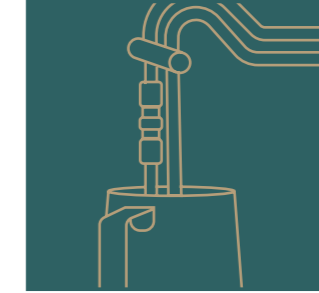

EASYCREAM optional

The technological solution to obtain, every time, the same milk cream, simply and quickly. Barista can create and set up to 9 milk/plant based drinks recipes, select them directly from the display home page and then pull the lever for the automatic steaming. The Easycream technology offers two different display modes (milk/coffee menu) to speedup the workflow.



HIGH PRODUCTION

The group with 5 pre-programmed buttons enables faster production and speeds up the workflow. The insulated stainless-steel boiler has an internal pressure of 2.1 bars that, working with the Steam-by-Wire electronic steam control, enable the dispensing of dry steam for a better drink quality and faster preparation.

COLOURS



Black



Stainless steel



Heritage



White

E1 PRIMA PRO



ALONGSIDE PIONEERS

E1 Prima PRO is the single group professional espresso machine for coffee specialists, roasters, chefs and mixologists who want to reach unexplored summits of quality, discover new boundaries of taste to savour the thrill of going where no one has gone before. The E1 Prima PRO is the most powerful single group Victoria Arduino has ever made. All standards are challenged and exceeded. This affects performance, control, flexibility of extraction, lightness and compactness.

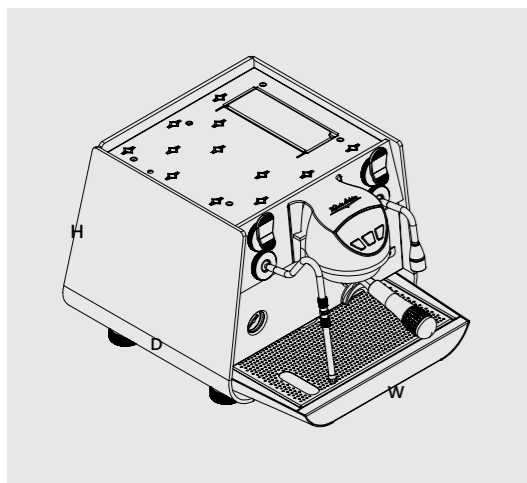

| | 1 Group |
|-----------------------------|---------------------|
| Width (mm) | 410 |
| Depth (mm) | 510 |
| Height (mm) | 380 |
| Group Height (mm) | 95 |
| Power (W) | Min 2000 / max 3100 |
| Net Weight (Kg) | 38 |
| Insulated boiler (L) | 1,8 |
| Insulated coffee boiler (L) | 0,6 |
| T3 genius | Standard |
| Pure Brew Technology | Standard |
| PB tech | Standard |
| Autopurge | Standard |
| Easycream | Opt. |

TECHNOLOGIES

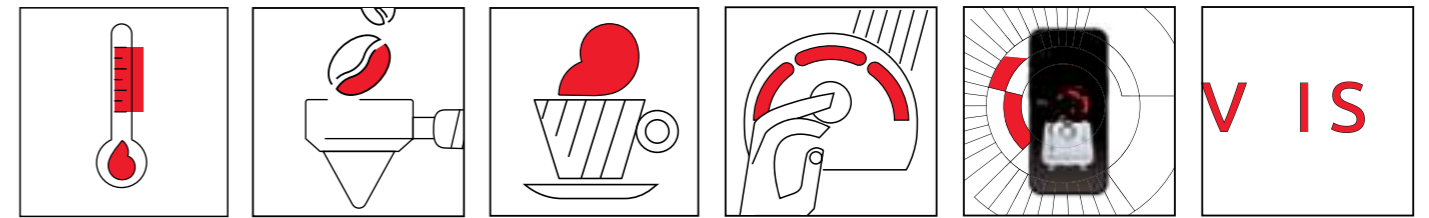

T3 GENIUS

Guarantees temperature control of the steam boiler, the coffee boiler and the group for maximum precision in the cup. The E1 Prima PRO Brew Temperature Reproducibility has obtained optimal results with perfect positioning within the range laid down by the World Coffee Events.

PURE BREW TECHNOLOGY

It's an innovative extraction method that is applied to espresso and to the extraction of a new drink without using pressure. Pure Brew pens to baristas a world of different recipes: from espresso to Pure Brew Coffee up to the extraction of tea and infusions to obtain perfect ingredients for mixing in cocktails and mocktails.

ADVANCED STEAM BY WIRE

A high quality drysteam delivery system at high pressure (2.1 bar) with the addition of two controls for splitting the steam between different sized jugs.

TOUCHSCREEN DISPLAY

The new 2.1" touchscreen display was designed to provide all information about the extraction, to be easy to read and to speed up every step of control and choice of setting.

VICTORIA ARDUINO E1 PRIMA APP

Just connect the Victoria Arduino E1 Prima app to the coffee machine and the system immediately recognises the model being used to offer a navigating experience and uniquely easy recipe setting. From the app user scan create different recipes espresso, PureBrew and milk based and share them on the app 'Cloud recipe' section.

VIS

VIS technology digitally estimates the right dose in the cup through algorithmic calculation. VIS brings improved workflow and the certainty of a great extraction making E1 Prima PRO an even better performing and smarter system.

COLOURS



White



Stainless steel



Black

EXCLUSIVE COLOURS



Bold Black



Racing Red

E1 PRIMA EXP



HELLO! LIFESTYLE EXPLORERS

E1 Prima EXP is the machine dedicated to those who love exploring different tastes through the research of quality ingredients and who treasure discovering and creating new drinks without sacrificing the beauty of a unique and contemporary object. Eagle One Prima EXP not only prepares many espresso and latte drinks but incorporates the new extraction method to create our signature drink, Pure Brew.

1 Group

| | |
|-----------------------------|---------------------|
| Versions | Volumetric |
| Width (mm) | 410 |
| Depth (mm) | 510 |
| Height (mm) | 380 |
| Group Height (mm) | 95 |
| Power (W) | min 1800 / max 2600 |
| Net Weight (Kg) | 37 |
| Insulated boiler (L) | 1,5 |
| Insulated coffee boiler (L) | 0,14 |
| NEO Technology | Standard |
| Pure Brew Technology | Standard |
| Autopurge | Standard |
| Easycream | Opt. |

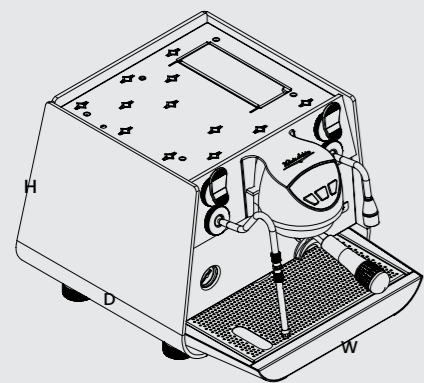

TECHNOLOGIES

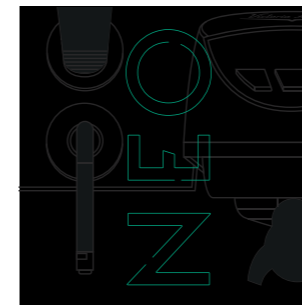

NEO TECHNOLOGY

New Engine Optimization is an exclusive technology that enables high performance and improves energy efficiency. All the barista has to do is set the temperature from the display. The NEO motor uses the instantaneous heating technology that requires smaller volumes and boilers because only the water that is needed is heated.

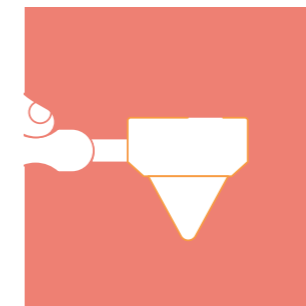

PURE BREW TECHNOLOGY

PureBrew technology, along with the new patented double-wall conical filter, provides the enjoyment of PureBrewCoffee, a filter coffee with unique characteristics, activated from the machine with a simple switch. Thanks to Pure Brew technology coffee lovers and baristas can extract a high-quality filter coffee or tea in less than three minutes and with a consistent result.



VICTORIA ARDUINO E1 PRIMA APP

Just connect the Victoria Arduino E1 Prima app to the coffee machine and the system immediately recognises the model being used to offer a navigating experience and uniquely easy recipe setting. From the app users can create different recipes espresso, PureBrew and latte based and share them on the app 'Cloud recipe' section.



EASYCREAM

The technological solution to obtain, every time, the same milk cream, simply and quickly. Easycream technology has a double wand that creams the milk and stops automatically as soon as the pre-set levels of temperature and milk cream have been reached. This is an extremely useful solution for speeding up the preparation of milk-based drinks, without loss of quality.

COLOURS



White



Stainless steel



Black

EXCLUSIVE COLOURS



Blue Pearl



Sparkling Coral



Metallic Lavander



Roman Coin

M200

La Cimbali introduces its new flagship, a true design icon created to stand out in any space. Every angle is designed to be seen, with no hidden sides. It combines futuristic style, solid engineering, and advanced technology with smart, intuitive ergonomics. Built for those who are passionate about great coffee and for the baristas shaping the future, today.



Technical Specifications

| M 200 | | | |
|-------------------------------------|--|----------------------|----------------------|
| | Two Group | Three Group | Four Group |
| L | 887 mm | 1087 mm | 1287 mm |
| L1 | 859 mm | 1059 mm | 1259 mm |
| L2 | 740 mm | 940 mm | 1140 mm |
| NET WEIGHT | 70 Kg | 92 Kg | 110 Kg |
| | 380-415 V3N 50-60 Hz | 380-415 V3N 50-60 Hz | 380-415 V3N 50-60 Hz |
| ELECTRICALS | 220-240 V3 50-60 Hz | 220-240 V3 50-60 Hz | 220-240 V3 50-60 Hz |
| | 220-240 V 50-60 Hz | 220-240 V 50-60 Hz | 220-240 V 50-60 Hz |
| POWER | 6,2-7,4 kW | 7,5-8,8 kW | 8,8-10,4 kW |
| HYDRAULIC CONNECTION | ø 3/8 gas | ø 3/8 gas | ø 3/8 gas |
| HYDRAULIC FEEDING PRESSURE | 1 ÷ 6 bar (0.6 MPa) | 1 ÷ 6 bar (0.6 MPa) | 1 ÷ 6 bar (0.6 MPa) |
| COFFEE BOILER CAPACITY | 0,6 L | 0,6 L | 0,6 L |
| HOT WATER AND STEAM BOILER CAPACITY | 7 L | 7 L | 7 L |
| AVAILABLE FINISHES | glossy white, matt black, polished aluminium (only M200 PROFILE) | | |

M23UP

This is yet another elegant, versatile commercial coffee machine from La Cimbali that is easy to use and maintain. Ergonomic and robust, the M23UP is made of steel. Its fixed-nozzle thermosyphon system is reliable and guarantees top performance, for excellent results in the cup every time. Lights on the coffee group (optional) can be used to illuminate the work space. This is specially designed for commercial usage like coffee shops, restaurants, QSRs and retail outlets.



| M23UP | | | |
|------------------------------|---------------------|---------------------|---------------------|
| | DT2 C2 | DT2 / C2 TALL CUP | DT2 / C2 TALL CUP |
| Multidirectional steam wands | 2 | 2 | 2 |
| Hot water wand | 1 | 1 | 1 |
| Boiler Capacity (L) | 11 | 11 | 17.5 |
| Power (W) | 4100-4800 | 4100-4800 | 5900-7000 |
| Electricals | 220-240V /50Hz/ 1Ph | 220-240V /50Hz/ 1Ph | 220-240V /50Hz/ 1Ph |
| Dimensions (WxDxH) mm | 820 x 518 x 552 | 820 x 518 x 552 | 1020 x 518 x 552 |
| Weight (Kg) | 63 | 63 | 78 |



LA CIBALI

Express Yourself



CLARKSON



Eklipto

Simplicity,
Styled

EKLIPTO offers a perfect balance of simplicity, style and flexibility.

Experience the perfect fusion of tradition and trend with the Elektra Eklipto—delivering iconic Italian craftsmanship wrapped in a bold, undeniably cool aesthetic



Simplicity

The Elektra Eklipto combines advanced performance with effortless simplicity, making it ideal for entry-level and mid-range coffee setups. With digital temperature control, electronic pre-infusion, dual steam wands, intuitive programming, and automatic cleaning, it ensures smooth and efficient operation.

More than an espresso machine, Eklipto is a statement piece. Its clean lines, bold geometry, mirrored stainless steel body, and warm wood handles create a refined balance of modern elegance and Italian craftsmanship, delivering both performance and style in every cup.





One Machine. Every Coffee.

The Elektra Eklipto is engineered for unparalleled versatility, making it the ideal choice for any coffee, from exquisite specialty beans to your daily blend.



Technical Specifications

| | 1GR | 2GR | 3GR |
|----------------------|---------------------------------|--|----------------------------------|
| Body material | | Stainless steel or painted metal | |
| Voltage | | 220-240V 50Hz /60Hz | |
| Power | 1850 W | 3150 W | 4350 W |
| Weight | 42 Kg | 58 Kg | 73 Kg |
| Dimensions | 560x588x470 | 860x588x470 | 1070x588x470 |
| Heating system | 51 Single boiler heat exchanger | 111 Single boiler heat exchanger | 141 Single boiler heat exchanger |
| PIO Control | | Included | |
| Coffee pump | 50l/h Rotative | 100l/h rotative | 200l/h rotative |
| Pressure gauge | | Duoble manometer, pump and steam pressure | |
| Brew head | | E6 I automatic professional brewing group | |
| Pre-Infusion | | Adjustable for each button | |
| Automatic cleaning | | Included | |
| Steam Wand | | Stainless steel cold touch with wood finishing | |
| Hot water wand | | Stainless steel with wood finishing | |
| Hot water wand | | 5 | |
| Display | | Included | |
| LED | | Included | |
| Boiler insualtion | | Optional | |
| Electical cup warmer | | Optional | |

Specifications are subject to change without prior notice due to continuous product development

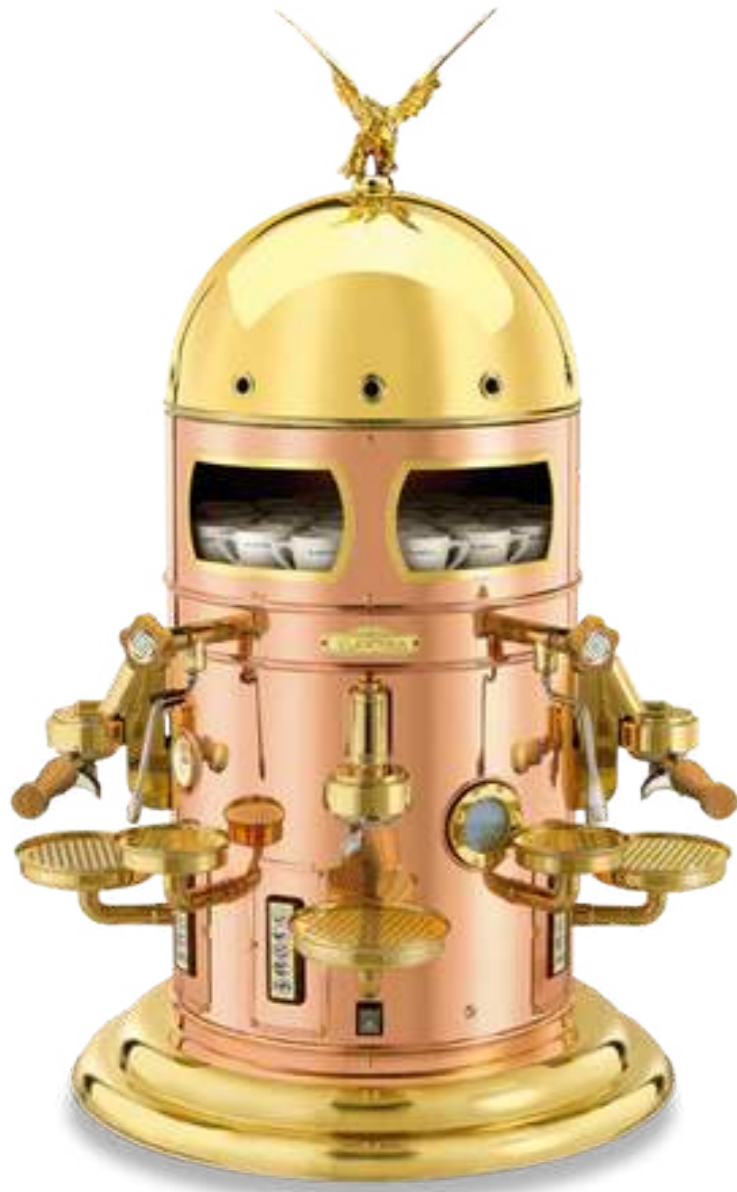

Elektra Belle Epoque

This stunning coffee machine from Elektra of Italy is available in India exclusively through Trufrost & Butler. It features a unique vertical design. The Belle Epoque (also known as the coffee machine with the eagle) exemplifies exceptional elegance, where beauty harmonises with functionality and reliability. Modelled with retro charm, it possesses a distinct character that enhances the choreography of refined and elegant spaces. This stylish coffee machine is a limited-edition offering for the most discerning buyers and coffee shops seeking to distinguish themselves from the crowd.



Technical Specifications

| Model | Belle Epoque |
|-------------------|--------------|
| Brand | Elektra |
| Rated input power | 3700 W |
| Electricals | 220V/50Hz |
| Boiler Capacity | 9L |
| Height mm | 890+190 mm |
| Diameter | Ø570 mm |
| Net Weight | 53 Kg |

Voltage: 220-240V/50Hz

Specifications are subject to change without prior notice

The technical features that characterize this machine are:

- ◆ Electronically programmable temperature for coffee and steam boilers
- ◆ Automatic coffee dispensing buttons with four programmable doses and a manual one
- ◆ Integrated 200l/m rotary pump with super silent technology
- ◆ Patented, inspectable heat exchangers
- ◆ Lead-free brass (OT57) dispensing units featuring high thermal properties
- ◆ Multidirectional steam wand and hot water tap
- ◆ Anti-torsion metal frame
- ◆ Automatic, independent group cleaning cycle
- ◆ ECO mode for saving energy



Make great coffee
with just a touch



Bean to cup coffee machines for every need



200 cups/day

Coffee Bar Pro-T



150 cups/day

Coffee Break Pro-T



150 cups/day

Coffee Break Premia



100 cups/day

Italia TurboSteam Pro



70 cups/day

Milano TurboSteam



Technical Specifications - Fully Automatic Coffee Machines



| Items | Coffee Bar Pro-T | Coffee Break Pro-T | Coffee Break Premia | Italia TurboSteam Pro | Milano TurboSteam |
|-----------------------------------|----------------------------------|-----------------------------|-----------------------|-----------------------------|-----------------------------|
| Brand | Dr. Coffee | Dr. Coffee | Butler | Butler | Butler |
| Advised daily output | 200 cups | 150 cups | 150 cups | 100 cups | 70 cups |
| Rated input power | 2900 W | 2900 W | 3100 W | 1500-1700 W | 1550 W |
| Electricals | 220V/50Hz | 220V/50Hz | 220V/50Hz | 220V/50Hz | 220V/50Hz |
| Pump Pressure | 19 Bar (Double Boiler System) | 19 Bar (2 Thermo blocks) | | 19 Bar (2 Thermo blocks) | 19 Bar (2 Thermo blocks) |
| Water Tank Capacity | - | 2L (Small) + 8L (Big) | 2L (Small) + 6L (Big) | 8 Litres + Tap Water | 2 Litres + Tap Water |
| Beans hopper capacity | 1200g x 2 | 1200g | 750g | 1200g | 500g |
| Powder hopper capacity (L) | 1.2L x 1 / 1.0L x 1 | - | - | - | - |
| Adjustable height of coffee spout | 80-165mm | 80-165mm | 75-155mm | 80-165mm | 80-120mm |
| Ground coffee container capacity | 70 portions | 70 portions | 50 portions | 70 portions | 20 portions |
| Drain water tray capacity | - | - | 2 Litres | 2 Litres | 0.7 Litres |
| Machine Weight | 26 kg | 26 kg | 20 kg | 17 kg | 14 kg |
| Dimensions (WxDXH) | 340x545x620 mm | 410x500x580 mm | 340x559x578 mm | 410x500x580 mm | 300x490x440 mm |

Specifications are subject to change without prior notice due to continuous product development



Milk Chillers

Refrigerated units from Trufrost with a real compressor in elegant black colour to go with your coffee machine. Frigo-Milk Premia preserve up to 8 (4+4) litres of milk. You can create the perfect light milk foam for trendy coffee creations by keeping the milk fresh and at a constant, cool temperature. It is taller and trendier with a digital temperature display on the door.



Frigo Milk Premia

Cup Warmers

The Butler electric cup warming units come in an all stainless steel construction. They have 2 cup warming shelves for preheating upto 72 cups for a real coffee experience. The special airflow ensures even heat distribution.



CW 2

Technical Specifications



| Model | Capacity | Temperature Range | Refrigerant | Dimensions WxDxH (mm) | Internal Cavity WxDxH (mm) | Power |
|-------------------|----------|-------------------|-------------|-----------------------|----------------------------|-------|
| Frigo Milk Premia | 9 Litres | 1-10 °C | R600a | 220x450x454 | 160x190x280 | 70 W |
| CW 2 | - | 60-85 °C | - | 360x320x550 | - | 14 W |

Voltage: 220-240V/50Hz

Specifications are subject to change without prior notice

4 steps to good coffee

- 1 Quality coffee beans
- 2 Freshly ground coffee powder
- 3 Good crema
- 4 Your favourite coffee



Manual and On-demand Coffee Beans Grinders

Butler Professional Coffee Grinders are built in an elegant combination of steel and black and are a perfect complement to your Traditional coffee machine. You can choose between an automatic grinder Ethos, manual grinder - Stride and Saga & Yoga on-demand doser-grinder that also has a digital display. Ethos grinds the beans by weight. They have single-bodied, hermetically sealed dosers that prevent aroma loss. The motor is equipped with a thermal protector.



Ethos



Saga



Yoga



Stride

*Available in white colour variant also.

Technical Specifications



| Model | Hopper Capacity | Dispenser Capacity | Display | Burr Adjustment | RPM | Flat Burr | Dimensions W X D X H (mm) | Power | Weight |
|--------|-------------------|---------------------|-------------------|-----------------|----------------------------------|-----------------------|---------------------------|-------|---------|
| Ethos | 1650 gms of beans | On demand by weight | 5.0" Touch screen | Digital | 800 - 2400 (Brushless DC Motor) | 83mm titanium | 230x290x550 | 800 W | 11 Kg |
| Saga | 1650 gms of beans | On demand | 5.0" Touch screen | Digital | 1360-2150 (Variable motor speed) | 83mm titanium | 290x380x700 | 680 W | 13.5 Kg |
| Yoga | 1650 gms of beans | On demand | 4.3" Touch screen | Manual | 1650 | 74mm titanium coating | 230x400x600 | 550 W | 13.5 Kg |
| Stride | 1650 gms of beans | Manual | - | Manual | 1360 | 64mm high-end metal | 230x400x600 | 420 W | 11 Kg |

Voltage: 220-240V/50Hz

Specifications are subject to change without prior notice



Mythos



GRINDING
PERFECTION.
AGAIN.

Mythos is the professional grinder that has been able, once again, to reach grinding perfection with important improvements from the points of view of user experience, grind control and design.

The official grinder of the World Barista Championship, Mythos defines a world of detail, but with a unique design, with the same passion and strong values to share with baristas, roasters and chains throughout the world once again to reach grinding perfection.

TECHNOLOGIES



CLIMA PRO

The proactive grinding system that offers maximum consistency of dose throughout the whole working day. All the barista has to do is set the grinding temperature from the display and the system does the rest: the probe positioned in the grinding chamber monitors the temperature, whilst the Clima Pro algorithm activates or deactivates the heating or cooling systems to constantly maintain the pre-set parameters.

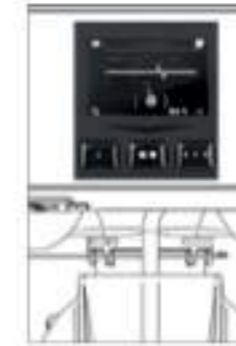

ELECTRONIC MONITORING OF GRIND SETTING

A solution that enables greater precision and grind regulation, but also an enormous time saving after cleaning: the system memorises the position and guides the barista to the grind setting.



GRAVITECH

Technology with incorporated scales and with an easily-set algorithm for fast calibration and dosage, thanks to a predictive system that automatically monitors dose precision and grinding speed. Greater flexibility, waste reduction and maximum precision are the immediately noticeable advantages even before first use.



CLUMP CRUSHER

Guarantees perfect flow of ground coffee into the portafilter, thus notably reducing cleaning and maintenance times, thanks also to better accessibility.



DISPLAY TOUCHSCREEN

The barista has full control over the information and settings thanks to the touchscreen display with its adaptive logic and thus highlighting all the most important information for his/her work, in real time, whilst maintaining routine data in the background.

COLOURS & VERSIONS

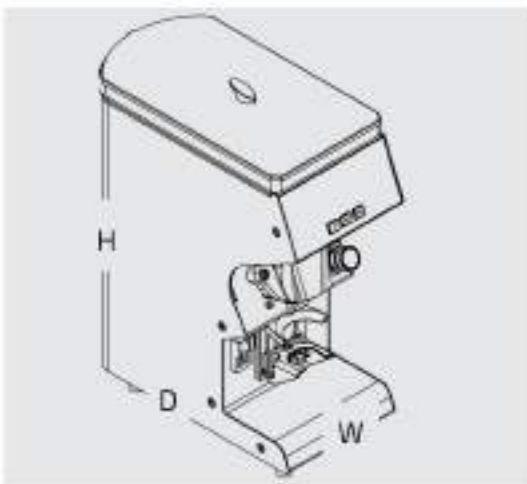

| | MYONE | MY75 |
|------------------|---------------------------------|---------------------------------|
| Width (mm) | 195 | 195 |
| Depth (mm) | 395 | 395 |
| Height (mm) | 479 | 479 |
| Bean hopper (kg) | 1,5 | 1,5 |
| Burrs (mm) | 75 | 75 |
| Power | 220 V / 400 W 110 V / 1200 W | 220 V / 600 W 110 V / 1200 W |
| Net weight (kg) | 23,7 | 23,8 |
| Dosage | Timed | Timed |



Black



White



Myone Black

Coffee accessories



Milk Pitcher
(350ml, 600ml, 1L)

MP-4-1, MP-4-2, MP-4-3



Milk Pitcher
(350ml, 600ml, 1L)

MP-13-1



Milk Pitcher
(350ml, 600ml, 1L)

MP-22-1

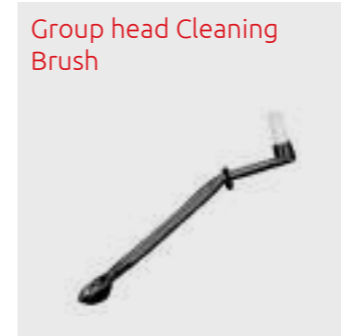

Group head Cleaning
Brush

BR-1

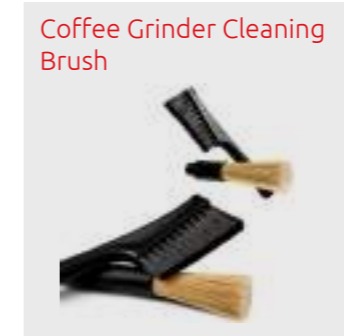

Coffee Grinder Cleaning
Brush

BR-4



Corner Tamping Mat Dual

CM-8



Coffee Tamber Seat

CM-7-2



Coffee Distributor
58mm

CD-15



Wooden Tamber 58mm
Beech Handle

TP-5

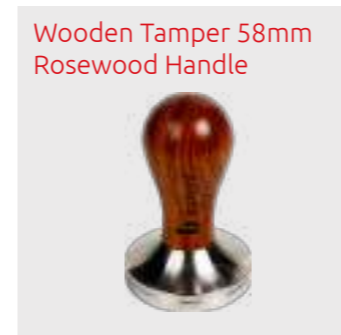

Wooden Tamber 58mm
Rosewood Handle

TP-6



Knock Box Chute with
Bottom Open

KB-2

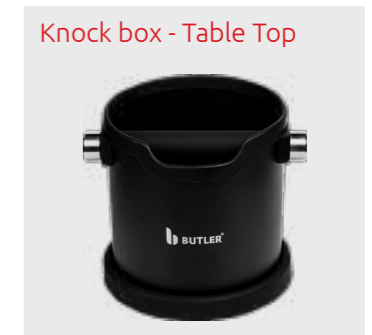

Knock box - Table Top

KB-6-2



Coffee Puck

KB-13-2



Drawer Knock Box

Knock out



Barista Cleaning Cloth

CMS-8-2

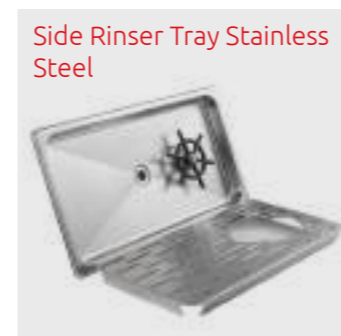

Side Rinsing Tray Stainless
Steel

CR-2

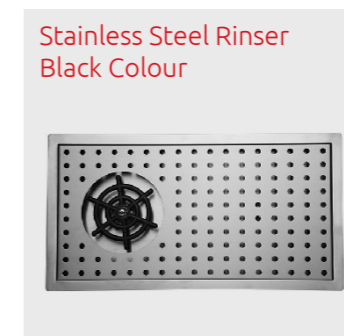

Stainless Steel Rinsing
Black Colour

CR-10



Cleaning Tablets (1gm)

N10



Cleaning Tablets (2.3gm)

F23



Cleaning Tablets (1.5gm)

S15



MFC Powder Eco For Milk
System

MFC



Grinder Cleaner

GC2



Espresso Machine Cleaning
Powder

EC2



When coffee meets cake

Great coffee needs to be complemented with great food. But its best companions are often cakes, pastries, croissants and deli. When displayed intelligently and smartly, they can be the real show-stoppers, magnetising your customers, and prompting them to make choices that enhance your food as well as beverage business.





Give your desserts the stage they deserve

Invariably, the most interactive area in any store is an inviting display of confectionery and savouries. Trufrost has a whole array of stylish and contemporary confectionery showcases that would do any convenience store, supermarket, café and cake shop proud. For a supermarket application, these display cases perfectly complement the other food retail equipment to create a holistic customer experience.



Why Trufrost confectionery showcases are miles ahead?

Reduce Food Wastage:

If your showcase display looks anything like this, it's time for an upgrade to Trufrost. Our display cases feature advanced double-tempered, heated front glass for clear visibility and condensation-free hygiene. A reliable ventilated refrigeration system with auto-defrost ensures uniform cooling, keeping everything from traditional Bengali mithais to exotic cheesecakes; fresh for longer.

Aesthetics:

Designed with an elegant blend of black glass and stainless steel, Trufrost display cases are enhanced with contemporary LED lighting under each shelf, creating a premium, international-style ambience that elevates your product presentation.

Conventional Display



Trufrost Display



elegance in simplicity

The elegance of flat glass showcases has taken over the modern design due to its sheer simplicity and clean lines. This lends a more modern look to the overall ambience and has become quite popular in the recent times.





Flat Glass Showcases - Premia Series

The Premia series Flat Glass Showcases from Trufrost are specifically designed to captivate your customers. The side and front glass feature a chic, Italian-style black lacquer border, while the base is meticulously crafted from stainless steel with a black titanium finish to enhance the premium look of your store's ambience. These stunning showcases are fitted with advanced, double-tempered heated front glass that improves visibility and prevents the unhygienic condensation often found in conventional display cases.



CSF 44 Premia
WSF 44 Premia

Flat Glass Showcases - Max series

The Max Series Flat Glass Showcases from Trufrost are designed for customers seeking strong performance and premium styling at an attractive price point. With a sleek black glass finish, enhanced visibility, and reliable cooling, these showcases are ideal for presenting desserts, bakery items, and confectionery in a visually appealing and hygienic manner.

- ◆ Double-tempered, heated front glass to minimise condensation
- ◆ High-definition, vacuum-sealed toughened glass
- ◆ Ventilated refrigeration system with gentle fan cooling
- ◆ Auto-defrost for consistent performance
- ◆ 4-tier display: base + 3 adjustable, angled shelves
- ◆ LED lighting under each shelf
- ◆ Digital temperature controller with temperature display
- ◆ Black lacquered glass border with matching black painted metal base
- ◆ Sliding rear doors for easy product loading
- ◆ Castors for effortless mobility and cleaning
- ◆ Optional warm showcase available in matching size



CSF 44 Max



3 Plus 2 Combination Display Showcase

This fashionable new product with an international appeal from the house of Trufrost comes with 3 feet wide cold display for cakes and confectionery that has a front heated glass that keeps the condensation away. It has an adjacent 2 feet of open chilled display that gives a magical look to the store ambience. The twin model comes in an overall 1500mm width and has a provision for 3 shelves apart from the base platform.



3 Plus 2 Premia



Crystal Tower Premia

Designed to create a stunning 360° display for cakes, beverages and gourmet treats that instantly elevates your store appeal. Featuring panoramic glass with LED lighting, ventilated refrigeration, auto defrost and a premium black titanium finish for uniform cooling and visual impact.



Panoramic Chiller Showcase



Frozen Tower (Panoramic Ventilated Freezer Showcase)

Crafted to showcase gelato and frozen desserts with maximum visibility and uncompromising elegance. Equipped with panoramic heated glass, ventilated refrigeration and adjustable shelves for crystal-clear display and consistent freezing performance.



Panoramic Freezer Showcase

the fashion
statement

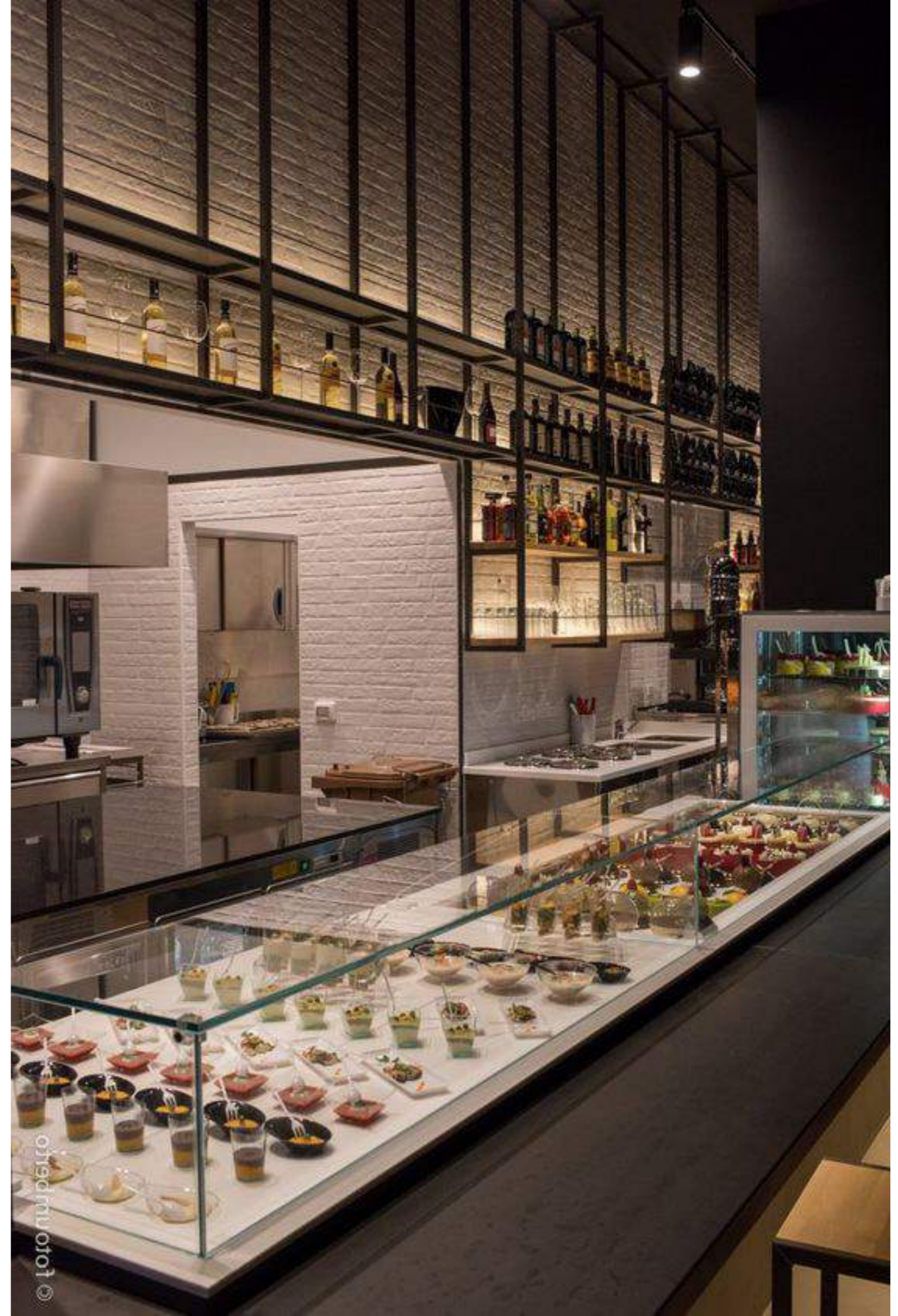

Diva

Inspired by the jewellery shop and high-end fashion boutiques, this jewellery box type display showcase from Trufrost is perfect for gorgeous creations especially, exotic pastries and chocolates. It has two refrigerated pull-out drawers at the rear and brilliant LED lighting to enhance the display. It also comes with an additional refrigerated storage underneath the drawers. You can place multiple units together to give a magical look to your store's ambience.



Diva 900 Premia
Diva 1200 Premia



Pull-out Drawers



Diva 42 Premia

over the counter



CTSR-23 Premia

Countertop Cold Displays

Suitable for showcasing and retailing Cakes, Pastries, Indian Desserts, Dairy Products, Cold Cuts, Sandwiches and Beverages. You can choose between two models that come in a dazzling combination of steel & glass, and fitted with a reliable, bottom mounted cooling system.



Baby Tower

Baby Tower

This newly launched stunning countertop cold display is suitable for showcasing and retailing Cakes, Pastries, Indian Desserts, Dairy Products, Cold Cuts, Sandwiches and Beverages. It comes in a dazzling combination of elegant black and glass, and is fitted with a reliable, bottom mounted cooling system.

display the warmth

Countertop Warm Displays

Suitable for showcasing and retailing a wide variety of appetizers and savouries like Samosas, Kachories, Patties, Wraps, Cutlets, Kathi Rolls and similar snacks. You can choose between 3 models that come in a dazzling combination of steel & glass. The model, CTW-4 is particularly suitable for displaying Halwas, Gulab Jamuns or similar Indian desserts that are served warm. FDW-3 is also suitable for displaying warm pizzas amongst other food items.



CTSW 23 Premia



CTW 4



FDW 3 x 660



Technical Specifications - Confectionery Showcases



| Model | Product | No. of Layers | | Dimensions W*D*H (mm) | Volume (Litres) | Temperature Range (°C) | Front Glass | Refrigerant | Power (Watts) |
|----------------------|--|---------------|------------------|--------------------------|--------------------|---------------------------|--------------|-------------|------------------|
| | | No. | Description | | | | | | |
| CSF 24 Max | Flat Glass 4 Layer Cake Showcase | 4 | Base + 3 shelves | 600*660*1300 | 240 | 2~8 | Heated | R 134a | 410 |
| CSF 44 Max | Flat Glass 4 Layer Cake Showcase | 4 | Base + 3 shelves | 1200*660*1300 | 530 | 2~8 | Heated | R 134a | 480 |
| CSF 24 Premia | Flat Glass 4 Layer Cake Showcase | 4 | Base + 3 shelves | 600*700*1300 | 240 | 2~8 | Heated | R 134a | 410 |
| CSF 34 Premia | Flat Glass 4 Layer Cake Showcase | 4 | Base + 3 shelves | 900*700*1300 | 390 | 2~8 | Heated | R 134a | 450 |
| CSF 44 Premia | Flat Glass 4 Layer Cake Showcase | 4 | Base + 3 shelves | 1200*700*1300 | 550 | 2~8 | Heated | R 134a | 480 |
| CSF 54 Premia | Flat Glass 4 Layer Cake Showcase | 4 | Base + 3 shelves | 1500*700*1300 | 670 | 2~8 | Heated | R 134a | 450 |
| CSF 34 | Flat Glass 4 Layer Cake Showcase | 4 | Base + 3 shelves | 900*730*1300 | 390 | 2~8 | Heated | R 134a | 450 |
| CSF 44 | Flat Glass 4 Layer Cake Showcase | 4 | Base + 3 shelves | 1200*730*1300 | 530 | 2~8 | Heated | R 134a | 450 |
| CSF 54 | Flat Glass 4 Layer Cake Showcase | 4 | Base + 3 shelves | 1500*730*1300 | 670 | 2~8 | Heated | R 134a | 450 |
| CSF 45 Tall Premia | Flat Glass 5 Layer Cake Showcase | 5 | Base + 4 shelves | 1200*740*1900 | 950 | 2~8 | - | R290 | 995 |
| WSF 44 Max | Flat Glass 4 Layer Warm Showcase | 4 | Base + 3 shelves | 1200*660*1300 | 530 | 40-65 | - | - | 450 |
| WSF 34 Premia | Flat Glass 4 Layer Warm Showcase | 4 | Base + 3 shelves | 900*700*1300 | 400 | 40-65 | - | - | 450 |
| WSF 44 Premia | Flat Glass 4 Layer Warm Showcase | 4 | Base + 3 shelves | 1200*700*1300 | 530 | 40-65 | - | - | 450 |
| WSF 54 Premia | Flat Glass 4 Layer Warm Showcase | 4 | Base + 3 shelves | 1500*700*1300 | 670 | 40-65 | - | - | 450 |
| WSF 44 | Flat Glass 4 Layer Warm Showcase | 4 | Base + 3 shelves | 1200*730*1300 | 530 | 40-65 | - | - | 450 |
| WSF 54 | Flat Glass 4 Layer Warm Showcase | 4 | Base + 3 shelves | 1500*730*1300 | 670 | 40-65 | - | - | 450 |
| 3 Plus 2 Premia | 3' Cake Showcase + 2' Open Showcase Chiller | 4 | Base + 3 shelves | 1500*700*1300 | 480 | 2~8 | Double Glass | R 290a | 930 |
| Crystal Tower Premia | 4 Side Glass Panoramic Cake Showcase | 5 | Base + 4 shelves | 675*695*1800 | 660 | 2~8 | Double Glass | R 290a | 590 |
| Frozen Tower | 4 Side Glass 5 Layers Panoramic Ventilated Freezer Showcase | 5 | Base + 4 shelves | 650*650*1950 | 319 | -18 ~ -22 | Double Glass | R 290a | 1000 |
| DIVA 1200 Premia | Jewellery Box Type Display for chocolate & confectionery | 1 | Base + 2 Drawers | 1200*850*1175 | 220 | 2~10 | Heated # | R 134a | 600 |
| DIVA 900 Premia | Jewellery Box Type Display for chocolate & confectionery | 1 | Base + 2 Drawers | 900*850*1175 | 160 | 2~10 | Heated # | R 134a | 500 |
| Diva 42 Premia | Jewellery Box Type 2 Layer Display for chocolate & confectionery | 1 | Base + 2 Drawers | 1200*850*1300 | | 2~8 | Heated # | R290 | 800 |
| Baby Tower | Desk Top Tall Display Refrigerator | 3 | Base + 2 shelves | 452*406*816 | 58 | 2~12 | Double Glass | R 134a | 190 |
| Mini Tower | Desk Top Tall Display Refrigerator | 4 | Base + 3 shelves | 430*390*986 | 78 | 2~12 | Double Glass | R 134a | 180 |
| CTSR 23 Premia | Countertop 3 Layer Square Glass Cake Showcase | 3 | Base + 2 shelves | 660*530*730 | 68 | 2~8 | - | R 134a | 160 |
| CTSW 23 Premia | Countertop 3 Layer Square Glass Warm Showcase | 3 | Base + 2 shelves | 660*530*730 | 68 | 40~65 | - | - | 450 |
| CTSR 23 | Countertop 3 Layer Square Glass Cake Showcase | 3 | Base + 2 shelves | 660*530*730 | 68 | 2~8 | - | R 134a | 160 |
| CTSW 23 | Countertop 3 Layer Square Glass Warm Showcase | 3 | Base + 2 shelves | 660*530*730 | 68 | 40~65 | - | - | 450 |
| CTW 4 | Countertop Warm Display Case | 1 | 4 x GN 1/3 pans | 773*420*336 | 67 | 30~90 | - | - | 500 |
| FDW 3 x 660 | Food Display Warmer with 3 Shelves | 3 | 3 shelves | 660*480*610 | 97 | 30~90 | - | - | 1480 |

Electricals: 220V/50Hz./Single Phase

Specifications are subject to change without prior notice due to continuous product development

Top glass also heated



India's favourite Commercial Microwave Oven

- ◆ Up to 100 programmable menu options for consistent results
- ◆ User friendly touch control pad
- ◆ 3 stage cooking and 5 microwave power levels
- ◆ See-through door with lighted interior
- ◆ Grab'n Go handle
- ◆ Stainless steel cabinet and oven cavity
- ◆ Removable splatter shield
- ◆ Stackable installation



MWO 34HD
MWO 34DM (Double Magnetron)



MWO 25

| Model | Dimensions W x D x H (mm) | Cavity Dimensions W x D x H (mm) | Cavity Volume (Litres) | Input Power (W) | Output Power (W) | Cooking Time (min:sec) |
|----------|------------------------------|-------------------------------------|---------------------------|--------------------|---------------------|---------------------------|
| MWO 25 | 511x311x432 | 327x200x346 | 25 | 1550 | 1000 | 3:10 |
| MWO 34HD | 553x488x343 | 370x385x230 | 34 | 1900 | 1400 | 2:30 |

*Throughput reflects one piece of Pizza

Specifications are subject to change without prior notice

Biryani



Biryani can be regenerated within minutes

Combo Meals



Combo meals can be regenerated within minutes

Lasagna



8 oz. lasagna can be cooked within 20 minutes and preheated in 3 minutes

Nachos



10 oz. nachos can be reheated within 2 minutes

Making fast food possible





Turn fast food into a gourmet experience



Pratica **FIT** EXPRESS

SPEED OVENS

The American sensation, now in India

The Pratica Fit Express high-speed oven is gaining popularity worldwide. It is designed to efficiently finish refrigerated, fresh, or frozen foods, such as breakfast sandwiches, chicken wings, muffins, lasagnes, subs, and other partially prepared dishes. It provides excellent flavour, appearance, and crispiness. The combination of impinged air and microwaves allows for faster heating, browning, or toasting of foods compared to traditional methods.



FIT Express



CERTIFIED
VENTLES
 WITH EASILY REMOVABLE
 CATALYTIC CONVERTER.

Market's most intuitive panel



- ◆ Compact size; suitable for 30cm pizzas.
- ◆ Full-colour, user-friendly touchscreen with drag-and-drop features.
- ◆ Stores menu recipes directly on the oven or via Wi-Fi or USB drive.
- ◆ Ventless: no hoods necessary.
- ◆ Removable catalytic converter for easy cleaning.
- ◆ Consistent results through precise control and even heat distribution.
- ◆ Independently adjustable microwave power, temperature, and impinged air.
- ◆ No side vents, allowing zero side clearance.
- ◆ Elegant and intuitive: stores unlimited recipes with their own steps, settings, icons, or photos.
- ◆ Temperatures up to 280°C: the impinged air convection technology combined with microwave capabilities enables faster cooking.
- ◆ Heat insulation keeps the surface cool to the touch.
- ◆ Single and dual magnetron versions available.

Standard Accessories



| Model | Voltage | Phases | Freq. (Hz) | Power (kW) | Circuit Breaker (A) | Cable | Socket | Product Dimensions (Height x Width x Depth) | Weight | Chamber Dimensions (Height x Width x Depth) |
|-------------|---------|--------|------------|------------|---------------------|----------------------|-------------|---|--------|---|
| FIT Express | 400V | Three | 50 | 6.8 | 16 | 5x2,2mm ² | 16A(3P+N+E) | 619x386x693 (mm) | 67 Kg | 170x315x341 (mm) |
| FIT SM | 230V | Single | 50 | 3 | 13 | 3x1,5mm ² | 13A(2P+E) | 619x386x693 (mm) | 67 Kg | 170x315x341 (mm) |

CE

Get great baking
results consistently



Modular Deck Ovens

The Butler Deck ovens offer you complete flexibility to stack multiple ovens on top of each other, enabling single-deck, double-deck, or triple-deck configurations. The Breadwinner series can also be placed atop the EDO series ovens shown on the facing page, providing various configurations for end users.



Breadwinner Series

- ◆ Boiler for effective steaming
- ◆ Single-deck two-tray version
- ◆ Modular: Can be stacked to create a 2-deck or 3-deck configuration
- ◆ Can also be paired with Black Italia Series ovens
- ◆ Digital controls with temperature setting up to 400°C

Black Italia Series

- ◆ Single-deck two-tray or 2-deck 4-tray models available
- ◆ Modular: Can be stacked to create a 3-deck configuration
- ◆ Can also be paired with Breadwinner Series ovens
- ◆ Comes with a stone that can accommodate 2 EN trays
- ◆ Digital controls with temperature setting up to 400°C



Breadwinner 1-2



Breadwinner 1-2
or EDO 1D-2T Black Italia
on top of

Breadwinner 1-2
or EDO 1D-2T Black Italia
or GDO 1D-2T Black Italia



EDO 2D-4T Black Italia
GDO 2D-4T Black Italia



Breadwinner 1-2
or EDO 1D-2T Black Italia
or GDO 1D-2T Black Italia
on top of

EDO 2D-4T Black Italia
GDO 2D-4T Black Italia

Technical Specifications - Deck Ovens 'Italia Series'



| Product | Model | Power | Gas Consumption | Weight | Dimensions (W x D x H) mm | Electricals | Temperature | Trays |
|--|------------------------|---------|-----------------|--------|---------------------------|----------------|-------------|--------------|
| Electric Single Deck Oven with Steam Boiler, Stone and Digital Control | Breadwinner 1-2E | 8.6 kW | - | - | 1260x945x615 | 1-220V / 50Hz | 0 ~ 400°C | 2 x EN Trays |
| Electric Two Deck Oven with Steam Boiler, Stone and Digital Control | Breadwinner 2-4E | 15.2 kW | - | - | 1260x945x1240 | 3-380V / 50 Hz | 0 ~ 400°C | 4 x EN Trays |
| Gas Single Deck Oven with Steam Boiler, Stone and Digital Control | Breadwinner 1-2G | 200 W | 0.36 kg/Hr | 120 Kg | 1060x675x1150 | 1-220V / 50Hz | 0 ~ 400°C | 2 x EN Trays |
| Gas Two Deck Oven with Steam Boiler, Stone and Digital Control | Breadwinner 2-4G | 200 W | 0.58 kg/Hr | 170 Kg | 1330x840x1355 | 1-220V / 50Hz | 0 ~ 400°C | 4 x EN Trays |
| Electric Single Deck Oven | EDO 1D-2T Black Italia | 6.6 kW | - | 94 Kg | 1260x855x565 | 1-220V / 50Hz | 0 ~ 400°C | 2 x EN Trays |
| Electric Two Deck Oven | EDO 2D-4T Black Italia | 13.2 kW | - | 161 Kg | 1260x825x1100 | 3-380V / 50 Hz | 0 ~ 400°C | 4 x EN Trays |
| Gas Single Deck Oven | GDO 1D-2T Black Italia | 100 W | 0.28 kg/Hr | 102 Kg | 1330x840x650 | 1-220V / 50Hz | 0 ~ 400°C | 2 x EN Trays |
| Gas Two Deck Oven | GDO 2D-4T Black Italia | 200 W | 0.56 kg/Hr | 170 Kg | 1330x840x1355 | 1-220V / 50Hz | 0 ~ 400°C | 4 x EN Trays |

Specifications are subject to change without prior notice due to continuous product development

Gas based ovens can work on LPG.





Electric Ovens & Proofers - Italia Series

This unified range of Butler Electric Ovens cum Proofers come in two variants - a 1 deck/ 2 tray or a 2 deck/4 tray electric oven built atop a 12 tray proofer. The outer cabinet is finished in brushed stainless. The oven is designed for baking bread, cakes, pastries and more. The required temperature can be set up to 400°C and controlled automatically. The 2 door proofer section at the bottom allows you to set the perfect temperature and humidity levels for consistent, repeatable results and can accommodate 12 pans (not supplied with the machines).



OVP 1212 Italia



OVP 1224 Italia

Technical Specifications - Electric Ovens & Proofers



| Product | Model | Power/ Gas Pressure | Weight | Dimensions (W x D x H) | Internal Dimensions of Each Oven (W x D x H) | Electricals | Temperature |
|---|-----------------|------------------------|----------|---------------------------|---|---------------|------------------------------------|
| 1 Deck 2 Trays Electric Oven With 12 Tray Proofer | OVP-1212 Italia | 9.2 kW | 125 kgs. | 1300 x 830 x 1420mm | 870 x 670 x 200mm | 380V / 50 Hz | 0-400°C (Oven) / 30-60°C (Proofer) |
| 2 Deck 4 Trays Electric Oven With 12 Tray Proofer | OVP-1224 Italia | 15.8 kW | 210 kgs. | 1300 x 830 x 1815mm | 870 x 670 x 200mm | 380V / 50 Hz | 0-400°C (Oven) / 30-60°C (Proofer) |
| 1 Deck 2 Trays Electric Oven With 12 Tray Proofer | OVP 1212 | 9.2 kW | 125 kgs. | 1300 x 830 x 1420mm | 870 x 670 x 200mm | 380V / 50 Hz | 0-400°C (Oven) / 30-60°C (Proofer) |
| 2 Deck 4 Trays Electric Oven With 12 Tray Proofer | OVP 1224 | 15.8 kW | 210 kgs. | 1300 x 830 x 1815mm | 870 x 670 x 200mm | 380V / 50 Hz | 0-400°C (Oven) / 30-60°C (Proofer) |
| Double Door Proofing Cabinet - 12 Trays | PC 12 Premia | 2.6 kW | 59 kgs. | 1250 x 815 x 905mm | - | 220V / 50 Hz. | 30-60°C |
| Tall Single Door Proofing Cabinet - 16 Trays | PC 16 Premia | 2.6 kW | 50 kgs. | 510 x 690 x 1910 mm | 500 x 640 x 1545 mm | 220V / 50 Hz. | 30-60°C |
| Tall Single Door Proofing Cabinet - 32 Trays | PC 32 Premia | 2.8 kW | 90 kgs. | 1010 x 690 x 1910 mm | 1000 x 640 x 1545mm | 220V / 50 Hz. | 30-60°C |

Specifications are subject to change without prior notice due to continuous product development

Trays not supplied with the machines.





Electric Convection Ovens

Butler convection ovens allow you to bake like a professional. They are designed for cooking or reheating croissants, chocolate buns, pastries or cookies, lasagna, baked potatoes and a wide variety of fresh frozen or pre-raised savories.

- ◆ Fan assisted heating ensures a quick rise in temperature up to 350°C
- ◆ Easy to clean chamber
- ◆ Double glass door; openable at 90° enables easy pullout of trays
- ◆ Advanced motor and heavy duty fan blades
- ◆ ECO-28-4T (New) comes with 4 trays



ECO-28-4T Premia



Technical Specifications



| Model | Power | Dimensions W x D x H (mm) | Chamber Dimensions W x D x H (mm) | Temperature Range | Trays |
|------------------|--------|------------------------------|--------------------------------------|----------------------|-------|
| ECO 28-4T Premia | 4.5 kW | 670 x 650 x 470 | 460 x 370 x 350 | 0°C - 350°C | 4 |

Voltage: 220-240V/50Hz

Specifications are subject to change without prior notice due to continuous product development

The convenience of modularity

Prodigy



Convection Oven

- 3 fan speed control
- Reverse fan for uniform baking
- Steam spray (with water box)
- Auto door opening after each baking cycle
- 5 - 350°C
- Space for placement of 5 EN trays

Deck Oven with Stone

- Steam function
- High quality stone
- Advanced digital controls
- 0 - 350°C
- Space for placement of 1 EN tray

Proofer

- Advanced digital controls
- Space for placement of 8 EN trays
- 0 - 110°C

Little Prodigy





Prodigy - Convex

Prodigy - Convex Modular Electric Convection Ovens

The Prodigy Convex from Butler is a premium convection oven engineered for consistent, high-quality baking. It features steam regulation, three fan speed controls, reverse airflow, and an auto side-opening hinged door to prevent overcooking. With digital controls, capacity for 5 x 1 EN trays, and an AISI 304 stainless steel chamber, it is ideal for croissants, pastries, cookies and bread.



Prodigy - Deck

Prodigy – Deck Modular Electric Deck Ovens

The Prodigy Deck from Butler is a precision-built deck oven designed for consistent baking performance. It features digital controls, integrated steaming function, premium pizza stone, and an AISI 304 stainless steel chamber for uniform heat distribution. Ideal for pizzas, bread, croissants and baked goods.



Prodigy - Pro

Prodigy - Pro Modular Proofing Cabinets

The Prodigy Pro from Butler is a premium stainless steel proofer with capacity for 8 EN trays (trays not included). Its modular, stackable design allows integration with Prodigy Deck and Convex ovens within the same footprint. Optimized for efficient workflow and space utilization.



Little Prodigy - Convex

Little Prodigy - Convex Modular Electric Convection Ovens

A compact convection oven with steam regulation, three fan speeds, and reverse airflow for even baking. Featuring advanced digital controls, automatic door opening, and a stainless steel AISI 304 chamber, it holds 5 trays (440x332 mm) — ideal for small bakeries and café setups.



Little Prodigy - Deck

Little Prodigy – Deck Modular & Compact Electric Deck Ovens

A powerful deck oven equipped with advanced controls, a premium pizza stone, steaming function, and an AISI 304 stainless steel chamber. Perfect for baking pizzas, breads, pastries, and more with consistent results.



Little Prodigy - Pro

Little Prodigy - Pro Modular Proofing Cabinets

A stainless steel proofer designed to hold up to 6 trays (440 x 332 mm). Its modular design allows stacking with the Deck and/or Convex ovens, maximizing efficiency while saving valuable floor space.

Technical Specifications



| Model | Power | Weight | Dimensions (W x D x H) | Cavity Dimensions (W x D x H) | Electricals | Temperature | Trays |
|------------------|--------|--------|------------------------|-------------------------------|----------------|-------------|--------------|
| Prodigy - Convex | 6.0 kW | 91 Kg | 840 x 849 x 789mm | 663 x 481 x 584mm | 3-380V / 50Hz* | 5 ~ 350°C | 5 x EN Trays |
| Prodigy - Deck | 4.7 kW | 51 Kg | 838 x 787 x 456mm | 610 x 456 x 212mm | 1-220V / 50Hz* | 5 ~ 350°C | 1 x EN Trays |
| Prodigy - Pro | 0.5 kW | 51 Kg | 838 x 745 x 830mm | 639 x 487 x 674mm | 1-220V / 50Hz* | 0 ~ 110°C | 8 x EN Trays |

Specifications are subject to change without prior notice due to continuous product development
* Unit supplied with both single phase and three phase power supply

Technical Specifications



| Model | Power | Weight | Dimensions (W x D x H) | Cavity Dimensions (W x D x H) | Electricals | Temperature | Trays |
|-------------------------|--------|--------|------------------------|-------------------------------|---------------|-------------|---------------|
| Little Prodigy - Convex | 3.5 kW | - | 636 x 669 x 639mm | 486 x 350 x 456mm | 1-220V / 50Hz | 5 ~ 350°C | 4 (400 x 332) |
| Little Prodigy - Deck | 3.6 kW | - | 635 x 687 x 456mm | 450 x 444 x 212mm | 1-220V / 50Hz | 5 ~ 350°C | 1 (400 x 332) |
| Little Prodigy - Pro | 0.5 kW | - | 636 x 647 x 647 mm | 520 x 377 x 592mm | 1-220V / 50Hz | 30 ~ 110°C | 6 (400 x 332) |

Specifications are subject to change without prior notice due to continuous product development
* Unit supplied with both single phase and three phase power supply



A wide range of pizza ovens



EPO 36 Black Italia
GPO 36 Black Italia



Neapolitan Forni



EPO 1D Premia



EPO 2D Premia

| Model | Power | Electricals | Temperature Range | Dimensions W x D x H (mm) | Output | Weight |
|-------------------------|--------|-----------------|-------------------|---------------------------|--------|--------|
| EPO 36 Black Italia | 3.2 kW | 220 - 240V/50Hz | 0-400°C | 920 x 605 x 490 | 5kg/H | 41 kg |
| GPO 36 Black Italia | 100 W | 220 - 240V/50Hz | 0-400°C | 1060 x 670 x 640 | 5kg/H | 65kg |
| Neapolitan Forni Premia | 5 kW | 380V/50Hz | 0-500°C | 950 x 905 x 420 | - | 68 kg |
| EPO 1D Premia | 2 kW | 220 - 240V/50Hz | 0-350oC | 560 x 570 x 280 | - | 24kg |
| EPO 2D Premia | 3 kW | 220 - 240V/50Hz | 0-350oC | 560 x 570 x 440 | - | 33kg |

*Gas Consumption: 0.24kg/hr Specifications are subject to change without prior notice due to continuous product development

Grill, Toast & more...





Contact Grills - Grooved

The Butler Euro Grill is an electric contact grill that is available in three variants featuring grooved top and bottom plates. These models are designed to leave grill marks and cook perfect jumbo-sized sandwiches, paninis, steaks, or hamburgers, retaining all juices and vitamins, or to grill fish, eggplant, or similar food items.



Euro Grill Junior DT



Euro Grill Jumbo



Euro Grill Jumbo DT

Technical Specifications

| Model | Power | Temperature Range | Dimensions W x D x H (mm) | Cooking Surface (mm) | Net Weight |
|-----------------------------------|--------|-------------------|---------------------------|----------------------|------------|
| Euro Grill Junior DT | 1.8 kW | 50°C-300°C | 290 x 305 x 210 | 218 x 230 | 13 Kg |
| Euro Grill Jumbo DT | 2.2 kW | 50°C-300°C | 410 x 305 x 210 | 360 x 285 | 15.5 Kg |
| Euro Grill Jumbo | 2.2 kW | 50°C-300°C | 410 x 370 x 220 | 360 x 285 | 15.5 Kg |
| Euro Grill (PG-11E) | 2.8 kW | 50°C-300°C | 430 x 310 x 200 | 340 x 230 | 25 Kg |
| Euro Grill Premia (PG-11E Premia) | 2.8 kW | 50°C-300°C | 425 x 400 x 210 | 340 x 230 | 21 Kg |

Electricals : 220 V Specifications are subject to change without prior notice due to continuous product development

Electric Griddle Plates



EGP 730GF



EGP 730F



EGP 550 (New)



Technical Specifications

| Model | Power | Electricity | Temperature Range | Dimensions W x D x H (mm) | Griddle Dimensions W x D x H (mm) |
|---------------|--------|---------------|-------------------|---------------------------|-----------------------------------|
| EGP 730 GF | 4.8 kW | 220V/50Hz/1Ph | 50°C-320°C | 730x470x250 | 728x468x10 |
| EGP 550 (New) | 3.0 kW | 220V/50Hz/1Ph | 50°C-320°C | 500x400x260 | 498x298x10 |

Electricals : 220 V

Specifications are subject to change without prior notice due to continuous product development



OMG 215 Premia



Multipurpose Grill

The OMG-215 from Butler is a multipurpose electric contact grill specially designed with flat top & bottom plates with a moulded cavity that makes it ideal for cooking or regenerating omelettes, paranthas, chillas, mini uttapams, mini dosas, pancakes or similar foodstuff that does not require grill marks. The round moulded cavity prevents fresh to be cooked omelettes or chillas or pancakes from overflowing or spilling while giving them a nice round shape.

- ◆ Easy to clean
- ◆ Timer and Touch Control Screen
- ◆ Cast iron plates for even cooking
- ◆ 10" diameter moulded cavity
- ◆ Self-balanced upper plate



Technical Specifications

CE

| Model | Power | Temperature Range | Dimensions W x D x H (mm) | Electricals | Net Weight |
|----------------|--------|-------------------|---------------------------|---------------|------------|
| OMG 215 Premia | 1.8 kW | 50°C-220°C | 360 x 478 x 218 | 220V/50Hz/1Ph | 15 Kg |

Specifications are subject to change without prior notice due to continuous product development

Countertop Fryers with Auto Lift

The EF-12 Auto from Butler is a high-performance professional fryer designed for speed, consistency, and convenience. Its standout **auto-lift feature** raises the fry basket above the oil at the end of each cycle, allowing excess oil to drain back into the tank — ensuring perfectly cooked, less greasy results every time.

Equipped with **computerized touch controls**, it enables operators to multitask with ease while maintaining precise frying consistency. Built for busy fast food environments, it's ideal for preparing chips, chicken, fish, onion rings, and more in quick succession using minimal oil. **Removable components** make cleaning simple and efficient, supporting smooth daily operations.



EF 12 Auto

Technical Specifications



| Model | Power | Capacity | No. of Baskets | Dimensions (W x D x H in mm) | Auto Lift | Voltage |
|------------|-------|----------|----------------|---------------------------------|-----------|-----------|
| EF 12 Auto | 3 kW | 12L | 1 | 270x585x380 | Yes | 220V/50Hz |

Specifications are subject to change without prior notice





EF 8 Europa DT



EF 4 Europa, EF 6 Europa,
EF 8 Europa



EF 8 Premia



EF 4, EF-6, EF 8



Countertop Fryers

These professional fryers from Butler are particularly suited for fast food restaurants. Suitable for frying chips, chicken, fish, onion rings in quick succession using minimal quantities oil. The model EF-8 Premia comes with computerised touch controls

- ◆ Precise bulb thermostat in stainless steel
- ◆ Heat resistant handles in baskets
- ◆ Removable parts for ease of cleaning
- ◆ 8 different models to choose from



Technical Specifications



| Model | Power | Capacity | No. of Baskets | Dimensions (W x D x H in mm) | Voltage |
|----------------|---------|----------|----------------|------------------------------|-----------|
| EF 4 Europa | 2 kW | 4 | 1 | 220x400x315 | 220V/50Hz |
| EF 6 Europa | 2.5 kW | 6 | 1 | 265x430x290 | 220V/50Hz |
| EF 8 Europa | 3.25 kW | 8 | 1 | 265x430x340 | 220V/50Hz |
| EF 8 Europa DT | 3.25 kW | 8 | 1 | 265x430x340 | 220V/50Hz |
| EF 8 Premia | 2.5 kW | 8 | 1 | 280x430x310 | 220V/50Hz |
| EF 4 | 2 kW | 4 | 1 | 220x390x370 | 220V/50Hz |
| EF 6 | 2.5 kW | 6 | 1 | 260x410x285 | 220V/50Hz |
| EF 8 | 3.25 kW | 8 | 1 | 260x410x340 | 220V/50Hz |

Specifications are subject to change without prior notice due to continuous product development



IDF 08 (New)

Twice as fast as conventional fryers



IDF 08 Rise



Countertop Induction Deep Fryers

This pioneering product from Butler uses patented technology and is ideal for frying in those places where other forms of heating and cooking are avoidable. No flames or hot surfaces provide for a safer, cooler kitchen. They are a boon for food-courts, airports, railways stations and similar applications.

Key Features

- ◆ Touch control
- ◆ 10 Quick setting mode available with IDF 08 Rise to store 10 programmes
- ◆ Stainless steel body
- ◆ Temperature range: 60°C-190°C
- ◆ Default temperature: 140°C
- ◆ Timer range: 0 - 15 mins, multiples of 30 seconds each
- ◆ Auto power-off: 4 hrs

Technical Specifications



| Model | Voltage | Power | Temperature Range | Dimensions (wxdxh) | Timer | Frypot Capacity |
|-------------|---------------|--------|-------------------|--------------------|------------|-----------------|
| IDF 08 Rise | 220-240V/50Hz | 3500 W | 60°C - 190°C | 288x478x410mm | 0-120 mins | 8 Ltrs |
| IDF 08 | 220-240V/50Hz | 3500 W | 60°C - 190°C | 288x478x410mm | 0-120 mins | 8 Ltrs |

Specifications are subject to change without prior notice





Gelato Panini Grill

'Ice on Fire' from Butler is a new, exciting concept in the frozen dessert business that allows you to add an interesting dimension to your menu. This easy-to-use Panini Grill turns gelato, soft serve, ice cream, or frozen yogurt into a creamy delight sealed in a golden-toasted bun. Garnished or mixed with a savory or sweet topping, scrumptious Gelato Panini can be served sliced on a plate or as a full sandwich in an on-the-go wrapper. Warm on the outside, and cold on the inside, this novel treat is sure to light up your business.



Cut bun in half and add gelato, ice cream or frozen yogurt



Seal it with the other half of the bun and place in the cavity, press and cook



Cut the creamy burger into 2 or more pieces and serve



Ice of Fire 100



Technical Specifications



| Model | Power | Electricals | Dimensions (WxDxH) mm |
|-----------------|--------|-------------|-----------------------|
| Ice on Fire 100 | 1300 W | 220V/50Hz | 250x540x315 |

Specifications are subject to change without prior notice



Waffle Bakers

The waffle bakers from Butler come with an electro-mechanical timer and can accept deep-frozen, frozen pre-cooked waffles or freshly made batter for making golden crispy waffles.

- ◆ Quick and even heat spread
- ◆ Temperature control range: 124°C ~ 230°C
- ◆ Time Control Range: 99 Minutes & 50 Seconds ~ 00 Minutes & 00 Seconds



WB 1



Technical Specifications

| Model | Power | Weight | Temperature Range | Dimensions (W x D x H in mm) | Time Control Range |
|-------|-------|--------|-------------------|------------------------------|--------------------|
| WB 1 | 2 kW | 10 Kg | 124°C ~ 230°C | 250x450x300 | 50Sec ~ 99Mins |

Voltage: 220-240V/50Hz

Specifications are subject to change without prior notice due to continuous product development



Chocolate Melter

The Butler Chocolate Melters are designed to not only melt your chocolate, but keep it at the perfect temperature throughout your food service. It comes with a covered stainless steel bowl, which is removable for easy cleaning. These can be used to melt Pure and Compound Chocolate, Hot Sauces and Chocolate Dips and more. It comes with a Temperature Controller to control the heat. Although the low wattage is designed to ensure that the chocolate does not get burnt, constant manual stirring is a must for optimal results.



CMM 4

Technical Specifications

| Model | Dimensions W x D x H (mm) | Tank Dimensions W x D x H (mm) | Temperature Range | Capacity | Power | Net Weight |
|-------|------------------------------|-----------------------------------|----------------------|----------|-------|---------------|
| CMM 4 | 203x355x292 | 176x 325x100 | 30~95°C | 4 Litre | 800W | 5.0 Kg |

Electricals: 220V/50Hz/1 Phase

Specifications are subject to change without prior notice due to continuous product development

The craft behind
captivating blends



Commercial Blenders with Acoustic Enclosure - Premia series

The TruBlend AQ Premia is a powerful commercial blender designed for cafés, bars, and juice outlets. It features a digital control panel for precise, consistent blending and an advanced acoustic enclosure that reduces noise by up to 80%. With a rugged 1.5L jar, metal connectors, and heavy-duty blades, it crushes ice effortlessly for smoothies, frappes, milkshakes, and more.



Trublend AQ Premia

Commercial Blenders with Acoustic Enclosure

The TruBlend Crush offers dependable commercial performance with easy manual controls, including a variable speed dial and pulse function for hands-on precision. Built for busy outlets, it crushes ice quickly and blends smoothies, shakes, and cold beverages with ease, while its acoustic enclosure ensures quieter operation.



Trublend Crush

Commercial Blenders

The Butler TruBlend is a reliable commercial blender ideal for cafés, juice bars, and busy food outlets. With simple manual controls, a variable speed dial, and pulse function, it offers precise blending control. Powerful blades crush ice in seconds, making it perfect for smoothies, shakes, frappes, juices, and cold coffee. The pulse feature also allows quick jar cleaning between uses.



TruBlend 1.8T

Technical Specifications



| Model | Dimensions (WxDxH) mm | Power | Motor Power | Jar Capacity | Net Weight | Timer |
|--------------------|-----------------------|--------|-------------|--------------|------------|--------|
| TruBlend AQ Premia | 240x280x540 | 1500 W | 2.25HP | 1.8 Litre | 11 Kg | Yes |
| TruBlend Crush | 240x267x502 | 1680 W | 2.25HP | 1.8 Litre | 8.85 Kg | Yes |
| TruBlend 1.8T | 240 x 280 x 515 | 1680 W | 2.2 HP | 1.8 Litre | Yes | 6.5 Kg |

Voltage: 220-240V/50Hz

Specifications are subject to change without prior notice

Single Spindle Drink Mixers

The Butler Drink Mixers offer great versatility for mixing drinks as well as food preparation. They are ideal for mixing ice cream shakes, 'lassi' or bar drinks and are equally handy for blending eggs or mixing batter for pancakes or waffles.



DM 1M



Technical Specifications

| Model | Power | Voltage | Shaft Speed (r/min) | Dimensions (WxDxH) | Net Weight |
|-------|-------|---------------|---------------------|--------------------|------------|
| DM 1M | 150 W | 220~240V/50Hz | 12000 / 18000 | 180x160x550 mm | 4.3 Kg |

Specifications are subject to change without prior notice due to continuous product development

Tireless performers

Refrigerated Reach in Cabinets

Trufrost Reach-Ins are available as Chillers or Freezers and come with 1, 2 or 4 door options. Suitable models for Coffee Shops come in 600 and 1200 litre capacities. Being vertical front door opening machines, they help save on precious space.



Models suitable for coffee shops →



G 600 TNM, G 600 BTM



G 1200 TNM, G 1200 BTM

Refrigerated Work Tables

Trufrost refrigerated work tables, mounted on heavy duty lockable castors, combine storage and preparation thereby enhancing the effectiveness of cafes and kitchen professionals. These are available as Chillers or Freezers and come with 2 and 3 door options



G2100TN, G2100BT



G3100TN, G3100BT



S 901



Technical Specifications



| Product | Model | Cooling System | Product Dimensions W*D*H (mm) | Volume (Litres) | Product Weight (Kg) | No. of Doors / Drawers | No. of Shelves | Temperature Range (°C) | Refrigerant | Input Power (W) |
|----------------------------|------------|----------------|-------------------------------|-----------------|---------------------|------------------------|----------------|------------------------|-------------|-----------------|
| Reach In Refrigerators | G 600 TNM | Ventilated | 680*710*2010 | 600 | 115 | 2 | 3 | 2~+10 | R134a | 220 |
| | G 1200 TNM | Ventilated | 1340*710*2010 | 1200 | 152 | 4 | 6 | 2~+10 | R134a | 465 |
| Reach In Freezers | G 600 BTM | Ventilated | 680*710*2010 | 600 | 126 | 2 | 3 | -22~-18 | R404A | 615 |
| | G 1200 BTM | Ventilated | 1340*710*2010 | 1200 | 161 | 4 | 6 | -22~-18 | R404A | 580 |
| Undercounter Refrigerators | G 2100 TN | Ventilated | 1360*600*850 | 228 | 83 | 2 | 2 | 2~+10 | R134a | 240 |
| | G 3100 TN | Ventilated | 1795*600*850 | 339 | 102 | 3 | 3 | 2~+10 | R134a | 230 |
| | S 901 | Static | 900*700*850 | 240 | 69 | 2 | 2 | +2~+10 | R134a | 180 |
| Undercounter Freezers | G 2100 BT | Ventilated | 1360*600*850 | 228 | 92 | 2 | 2 | -22~-18 | R404A | 615 |
| | G 3100 BT | Ventilated | 1795*600*850 | 339 | 114 | 3 | 3 | -22~-18 | R404A | 615 |

Electricals: 220V/50Hz/1 Phase Specifications are subject to change without prior notice due to continuous product development
Please refer to information given next to the product picture.



Ice Machines

Highly relevant for commercial outlets where space is at a premium, the self contained Trufrost Ice Machines present the best options for coffee shops and restaurants and can also be used for undercounter applications.

- ◆ Contemporary, elegant design available in ice production capacities ranging from 18 to 910 kg per day
- ◆ Insulated ice storage bin and door minimize air condensation and water formation
- ◆ IC 18BW also comes with a cold water dispensing option
- ◆ IC 35BWA & IC 50BWA models have the option of accommodating a bottled water jar on top
- ◆ IC-25 Premia, IC35BWA, IC-50BWA & IC-100 models are also suitable for undercounter applications so long the recommended circulation space can be provided for the discharged hot air from the machine.
- ◆ IC-25 Premia can also be placed over the counter.



IC 25 Premia

IC 35BW Premia, IC 55BW Premia, IC 55BW Premia XL

IC 100 Premia

IC 220 Premia on ISB 150 Bin, IC 350 Premia, IC 460 Premia on ISB 220 Bin

IC 1000 Premia on ISB 460 Bin

Technical Specifications



| Model | Capacity / 24 hrs.* | Ice Storage Capacity | Cube Shape / Size (mm) | Refrigerant | Electricals | Power (w) | Dimensions wxdxh (mm) | Compatible Storage Bin |
|--------------------|---------------------|----------------------|------------------------|-------------|-------------|-----------|-----------------------|------------------------|
| IC 25 Premia | 25 kgs. | 6.0 kgs. | Dice / 28*28*23 | R404a | 220V/50Hz | 180 | 380*470*600 | - |
| IC 35 BW Premia | 30 kgs. | 15 kgs. | Dice / 28*28*23 | R404a | 220V/50Hz | 280 | 500*450*830 | - |
| IC 55 BW Premia | 50 kgs. | 18 kgs. | Dice / 28*28*23 | R404a | 220V/50Hz | 320 | 500*590*830 | - |
| IC 55 BW Premia XL | 50 kgs. | 18 kgs. | Dice / 35*35*23 | R404a | 220V/50Hz | 320 | 500*590*830 | - |
| IC 100 Premia | 98 kgs. | 45 kgs. | Dice / 28*28*23 | R404a | 220V/50Hz | 600 | 660*680*930 | - |
| IC 220 Premia | 220 kgs | 150 kgs. | Dice / 28*28*23 | R404a | 220V/50Hz | 850 | 560*830*1600 | ISB-150 |
| IC 350 Premia | 350 kgs. | 220 kgs. | Dice / 28*28*23 | R404a | 220V/50Hz | 1200 | 760*830*1600 | ISB-220 |
| IC 460 Premia | 460 kgs. | 220 kgs. | Dice / 28*28*23 | R404a | 220V/50Hz | 1600 | 760*830*1800 | ISB-220 |
| IC 1000 Premia | 950 kgs. | 460 kgs. | Dice / 28*28*23 | R404a | 380V/50Hz | 4500 | 1220*930*1980 | ISB-460 |

* At 10°C incoming water and 10°C air temperature Height & width for IC 220/350/460/1000 is with the suggested storage bin
Specifications are subject to change without prior notice due to continuous product development

Flat Packed Stainless Steel Furniture

The knocked down stainless steel furniture range from Butler perfectly complements its cooking and food preparation equipment. Built in solid 0.8mm stainless steel, it is easy to install and aims to comprehensively address the equipment needs of commercial kitchens.



Work Tables with Splash Back



Work Tables



Stands with 4 shelves



Single Layer Wall Shelves





Discover more at
www.kanteenindia.com

TRUFROST & BUTLER

KANTEEN INDIA EQUIPMENTS CO.

CB-59, Sector 1, Salt Lake City, Kolkata 700064, WB, India

Customer Care: +91-8100-777-000

E-mail: sales@kanteenindia.com | service@kanteenindia.com

Website: www.kanteenindia.com



@kanteenindia

